



Product Information

CU4-SOPRANO • *CompactPCI*® Quad Serial Interface

Document No. 2893 • Edition 2006-08

Still the most common industrial data transfer method: the asynchronous serial interface according to RS-232 and RS-485.

The *CompactPCI*® card CU4-SOPRANO is provided with a quad UART. The line transceivers are individually configurable according to either RS-232E or RS-485.

The quad PCI UART is compatible to the widespread 16C550/650 series. Drivers are available by download for nearly all popular operating systems.

The CU4-SOPRANO is suitable for a variety of industrial applications, e.g. data acquisition, PXI measuring systems or process control.



All ports are directly available from the CU4-SOPRANO front panel. Due to the height of 3U, the board is provided with four RJ45 Jacks. Integrated LEDs signal status information. An external adapter is available from RJ45 to DB9 (D-Sub connector) in order to maintain PC COM port compatibility.

Each port allows individual transceiver configuration according to either RS-232E or RS-485/422 by a single jumper. In addition, all 4 UART channels are wired as TTL-level signals to the rear connector J2 (option). By employing the CU9-BASE rear I/O transition board and PHY transceiver modules (CU7 and CU8 series), all ports are alternatively available from the back panel.

The drivers allow arbitrary names e.g. COM4..COM8 to be associated with the ports of the CU4-SOPRANO.

The CU4-SOPRANO is a 3U board (single size Eurocard). For use in 6U systems, the front panel expansion kit CR9-ADAPT is available.

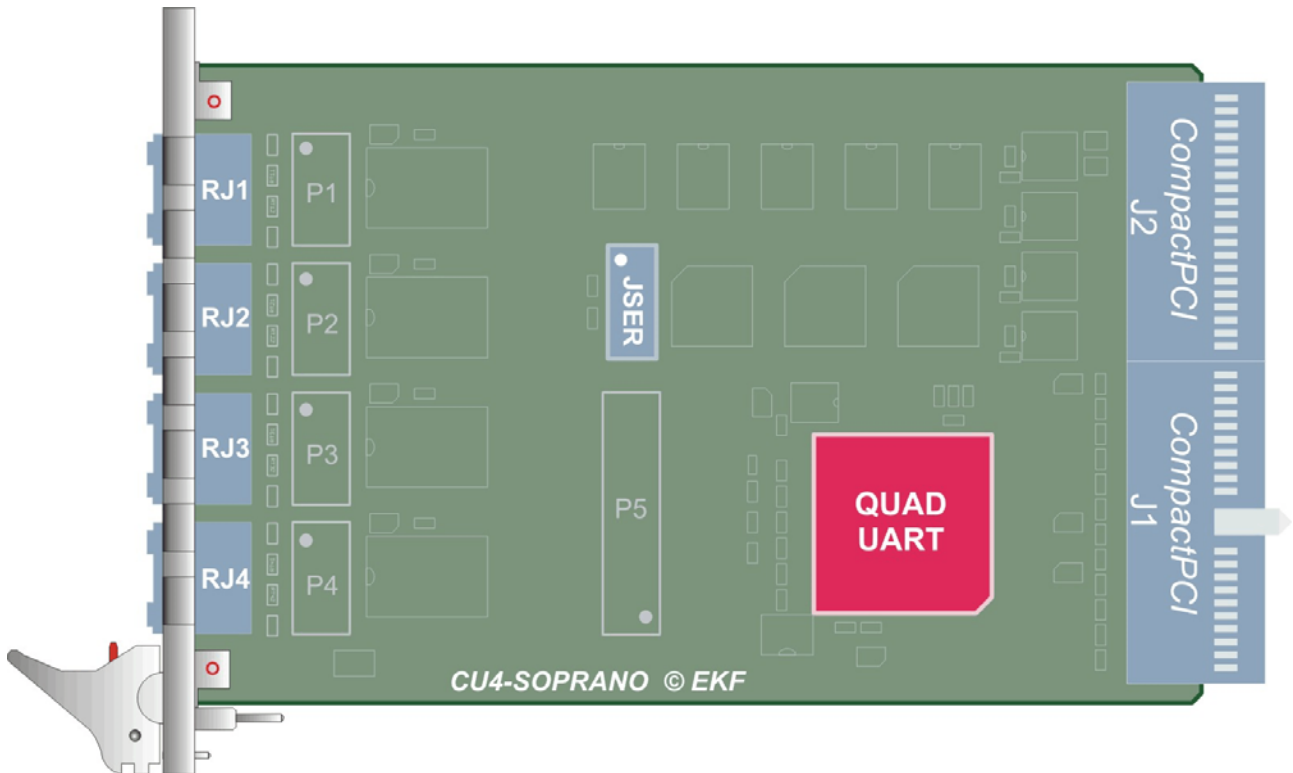

Assembly Drawing

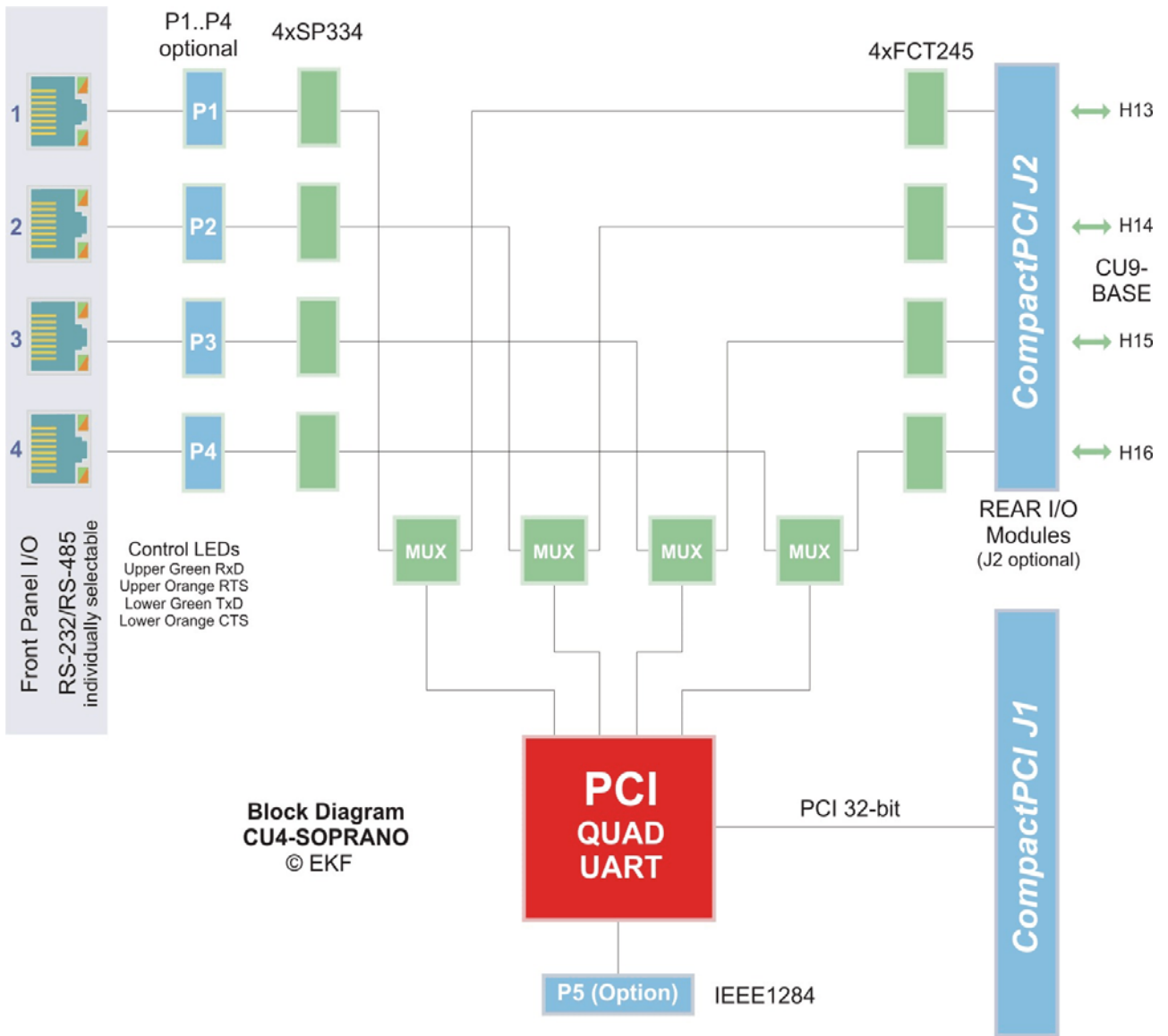

Block Diagram CU4-SOPRANO

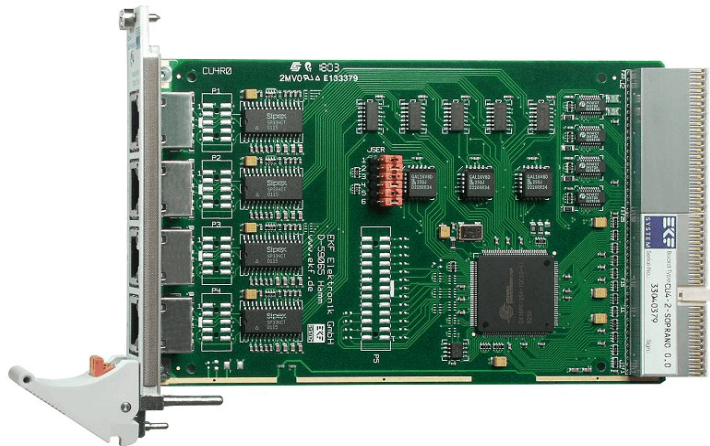

Feature Summary CU4-SOPRANO

Form Factor	Single size <i>CompactPCI</i> style Eurocard (160x100mm ²), front panel width 4HP (20.3mm)
Serial Interfaces	<ul style="list-style-type: none"> ▶ Asynchronous, serial protocol: 1 start bit; 7 or 8 data bits; 1 or 2 stop bits; optional even/odd parity; standard bit rates RS-232E up to 230.4 kbps ▶ Quad PCI UART OX16PCI954, compatible with 16C550 (and in addition 16C450, 16C650, 16C750, 16C950), FIFO 1/16/128 Byte, automatic software flow control (XON/XOFF), automatic hardware flow control (CTS/RTS, DSR/DTR) ▶ RS-232E or RS-485 (EIA/TIA-485) full-duplex (Rx/D/TxD) individually selectable for each port, dual-mode transceiver SP334 (up to 230.4kbps with RS-232, 921.6kbps and above with RS-485), 2kV ESD protection ▶ 4 x RJ45 8-pos. I/O connectors in the front panel, integrated status LED display for Rx/D/TxD/RTS/CTS, external adapter RJ45 to DB9 available as accessory ▶ Optional 4 x 10-position pin headers P1-P4, dual-row 2 x 5, 2.54mm pitch, suitable for optional attachment of a flat cable assembly with a DB9 connector at the opposite end (PC COM Port compatible when RS-232 is selected) ▶ Additionally all UART ports available as buffered TTL signals across <i>CompactPCI</i> J2 connector for external transition-board CU9-BASE and PHY modules CU7/CU8 (option only, J2 must be omitted for 64-bit CPCI bus slots) ▶ Serial drivers for Microsoft® Windows® 98/ME/NT4/2000/XP available by download
Parallel Interface (Option)	<ul style="list-style-type: none"> ▶ Optional pin header P5, 2x13 position, 2.54mm pitch, for optional attachment of a flat cable assembly with a DB25 connector at the opposite end (PC LPT port compatible), complies with IEEE-1284 EPP parallel port standard ▶ Drivers for Microsoft® Windows® 98/ME/NT4/2000/XP available by download ▶ Special board version CU4-P-SOPRANO available with front panel LPT printer port connector D-Sub 25
<i>CompactPCI</i> [®]	CPCI bus master 32-bit 33MHz, +5V V _{IO} interface (blue keying on J1 connector)
Rear I/O (Option)	Optional J2 connector for attachment of a rear I/O transition module CU9-BASE
Power Requirements	+5V ±5% 0.4A max. (optional consumption of external PHY-modules not included)
Thermal Conditions	<ul style="list-style-type: none"> ▶ Operating temperature range 0°C ... +70°C (industrial temperature range on request) ▶ Storage temperature range -40°C ... +85°C, max. gradient 5°C/min
Environmental Conditions	<ul style="list-style-type: none"> ▶ Humidity 5% ... 95% RH non condensing ▶ Altitude -300m ... +3000m ▶ Shock 15g 0.33ms, 6g 6ms ▶ Vibration 1g 5-2000Hz
EC Regulations	<ul style="list-style-type: none"> ▶ EN55022, EN55024, EN60950-1 (UL60950-1/IEC60950-1) ▶ 2002/95/EC (RoHS)
MTBF	350,000h

Specifications are subject to change without further notice

The quad UART is equipped with a flexible bit rate generator, which can be matched with a variety of oscillator frequencies for virtually any Baud rate. By default, the CU4-SOPRANO provides a 1.8432MHz oscillator. Several UART registers affect the prescaler (CPR), the divisor and the sampling rate (TCR). It is the task of the drivers to manage these registers adequately.

Selected Oscillator Options				
Oscillator (MHz)	CPR (Prescaler)	Clock effective (MHz)	max. Baud rate CPR=1 TCR=16	max. Baud rate CPR=1 TCR=4
1.8432	0x08 (1)	1.8432	115,200	460,800
3.6846	0x10 (2)	1.8432	230,400	921,600
7.3728	0x20 (4)	1.8432	460,800	1,843,200
14.7456	0x40 (8)	1.8432	921,600	3,686,400
18.432	0x50 (10)	1.8432	1,152,000	4,608,000
50.000	0xd9 (27.125)	1.8433	3,125,000	12,500,000

With an effective clock of 1.8432MHz and the sampling register TCR containing a value of 16, the typical Baud rates of a PC COM port can be achieved with the following divisor register values:

DLM:DLL	Baud rate
0x0001	115,200
0x0002	57,600
0x0003	38,400
0x0004	28,800
0x0006	19,200
0x000c	9,600
0x0018	4,800
0x0030	2,400
0x0060	1,200
0x00c0	600
0x0180	300
0x0300	110
0x0900	50

Front Panel Connectors

RJ1..RJ4 Serial ports 1..4, 4 x RJ45 jack, 4 integrated LEDs each signal data transmission (RxD, TxD) and hardwired-handshake (CTS, RTS), external adapters custom configurable RJ45 to DB9 male or female available as accessory

RJ1 .. RJ4

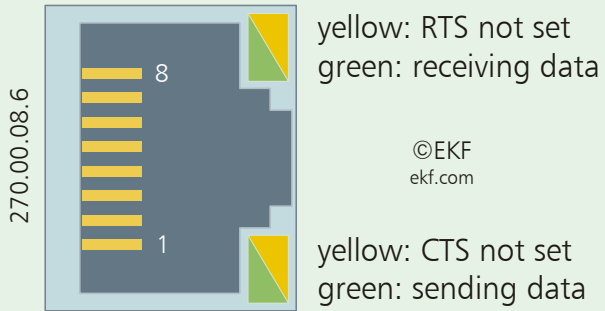

©EKF
ekf.com

red = input blue = output

RS-232	Pin #	RS-485
DSR	1	do not use
DCD	2	do not use
DTR	3	do not use
GND	4	GND
RXD	5	RXD -
TXD	6	TXD +
CTS	7	RXD +
RTS	8	TXD -

External adapters from RJ45 to DB9 plug (male) or receptacle (female) are available, which are pre-assembled for custom configuring. By means of a pliers or inserting tool, the jumper wires from the RJ45 jack are ready to be pushed into the appropriate spot on the DB9 connector. The adapter itself must be connected to the corresponding RJ(1..4) jack of the CU4-SOPRANO. A suitable cable requires all 8 leads wired up straight forward 1:1. A short Ethernet patch cable could be used (avoid cross over patch cables, or old 4-wire Ethernet cables, or ISDN cables).

A male DB9 connector is required to emulate the serial RS-232 interface (COM port) of a desktop PC. The adapter must be wired up according to the scheme below. Due to one missing signal line, the modem-signal RI (Ring Indicator) is not available across the RJ45 jacks.

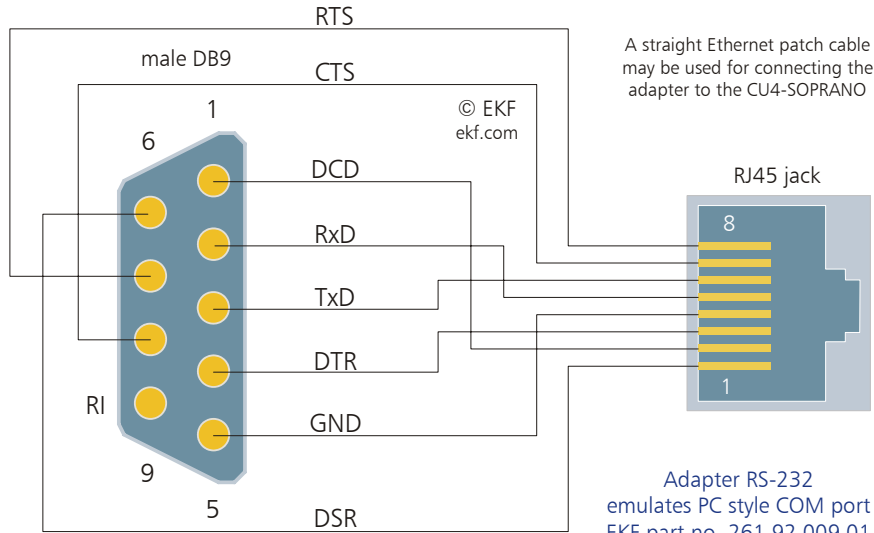

In order to OPERA to a adapter with a connector can be directly attached to the COM port of the PC. The wiring scheme of the adapter emulates a null-modem cable. A typical configuration is shown in the diagram below.

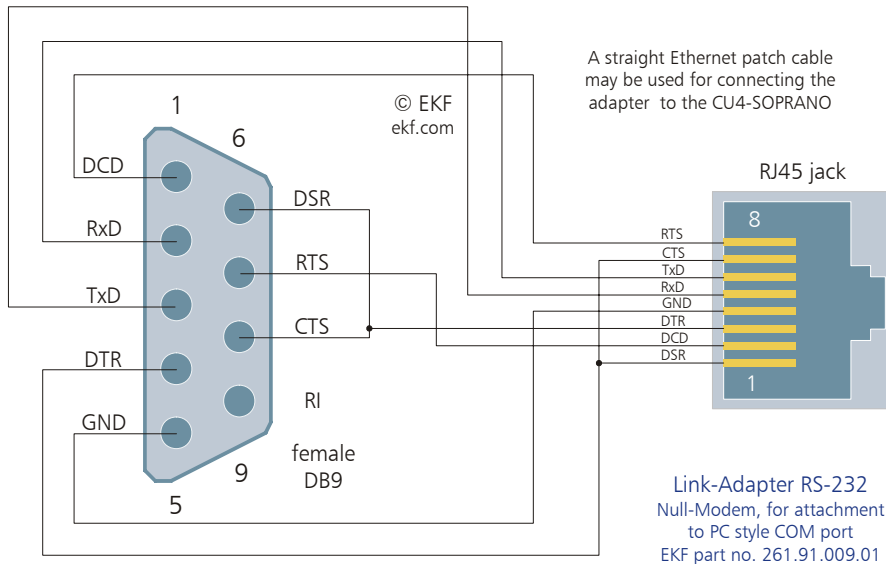

There is no explicit standard in use for RS-485 across DB9 connectors, instead several proprietary solutions coexist. If the above adapter wiring scheme for RS-232 with a male DB9 would be used also for RS-485, the assignment of the differential signals can be derived from the diagram below:

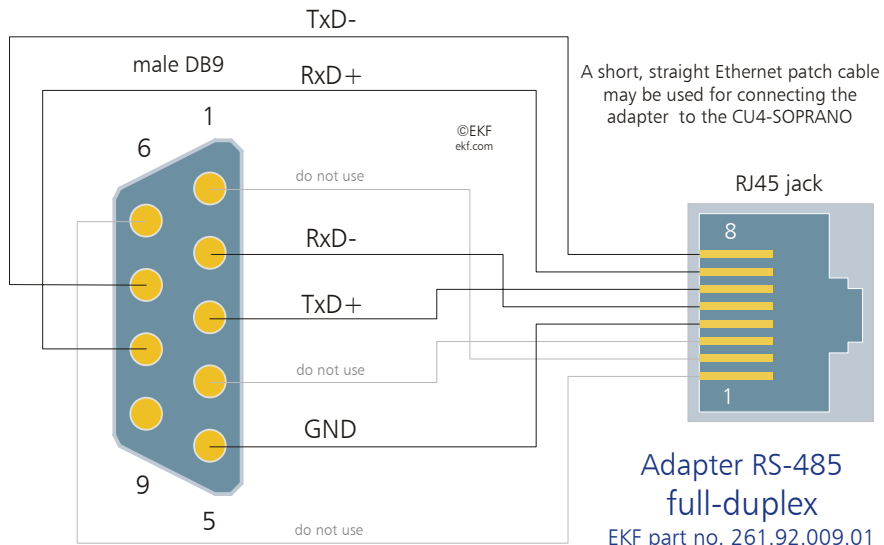

Adapters RJ45 to or 25-position) from several distributors, but can also ordered directly from EKF. Please note, that the adapters are preassembled kits only, which must be configured (strapped) by the customer itself to fit his requirements. For volume quantities, please contact EKF in order to receive a quote on ready to use configured adapters.

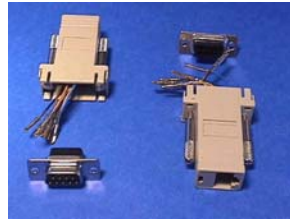

The following principle schematic shows the serial transceivers in the RS-232 mode:

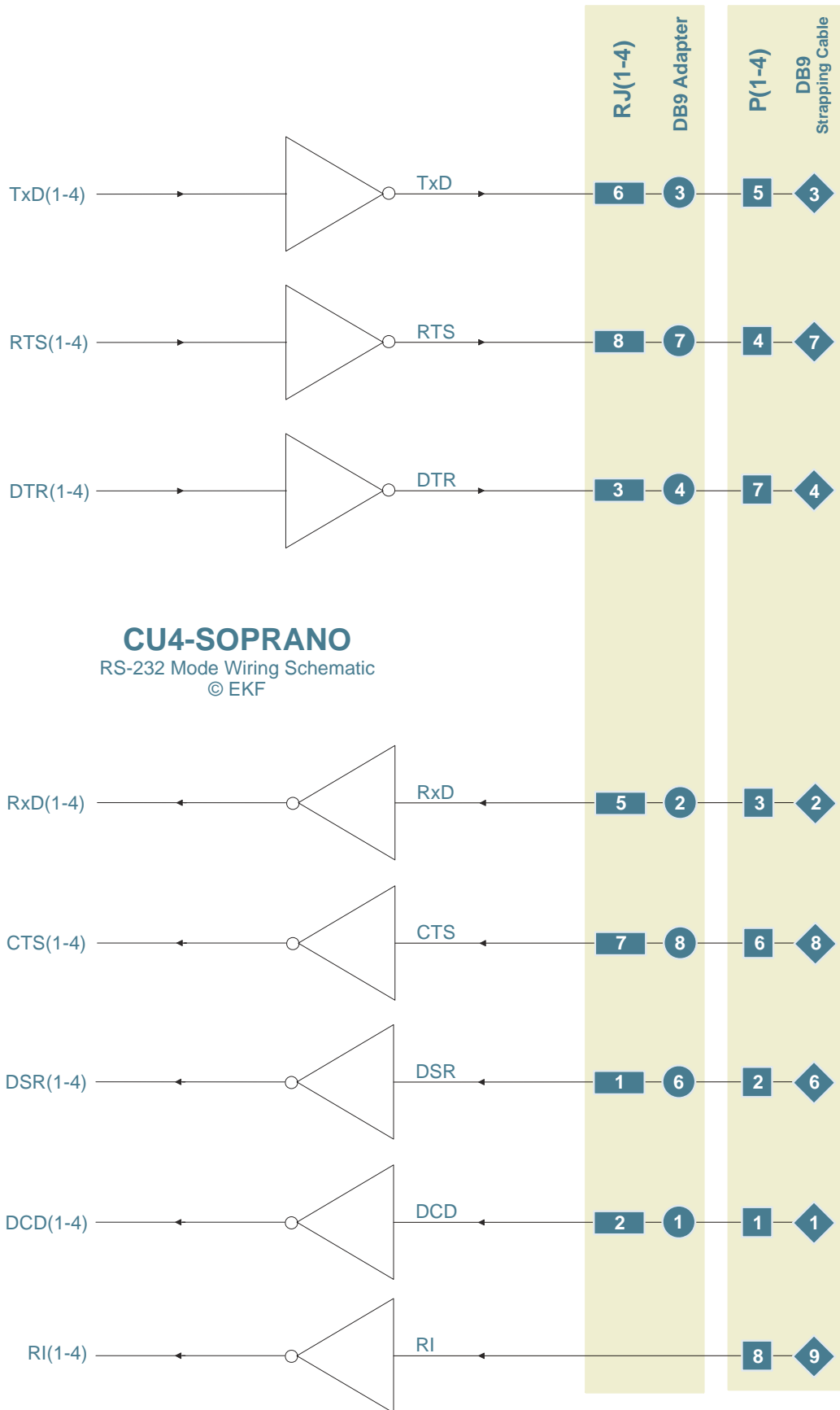

The principle schematic below shows the serial transceivers in the RS-485 Mode:

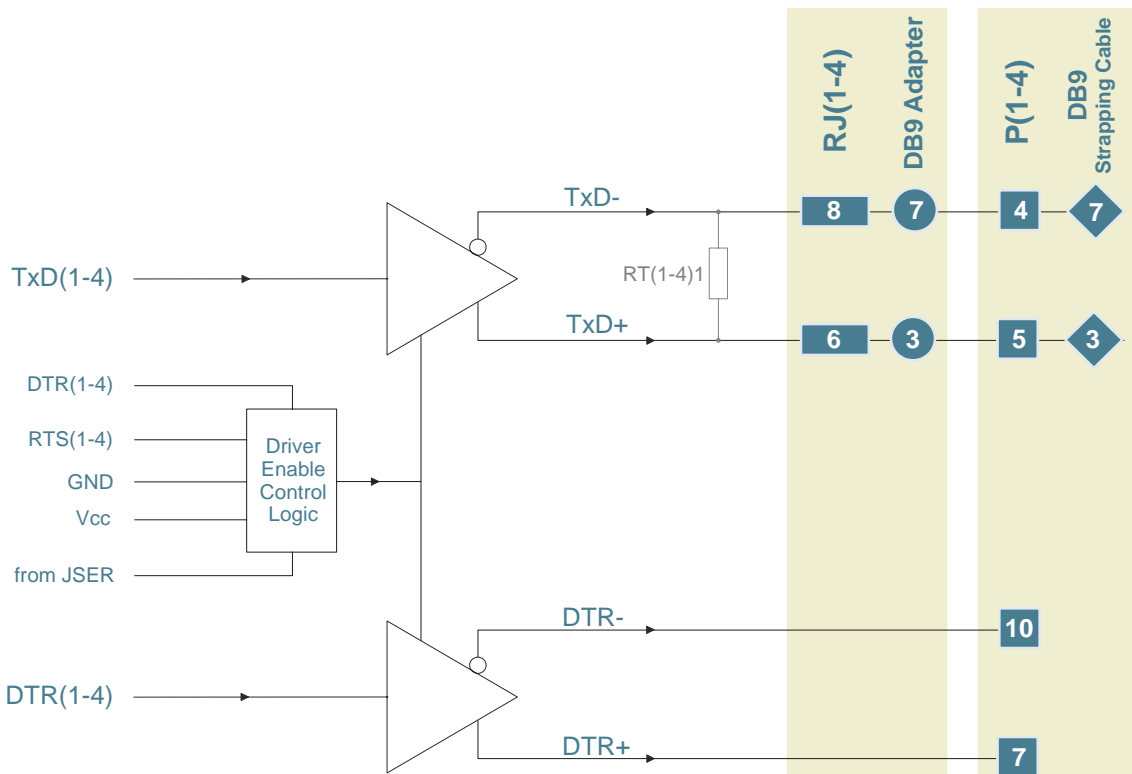

CU4-SOPRANO
RS-485 Mode Wiring Schematic
© EKF

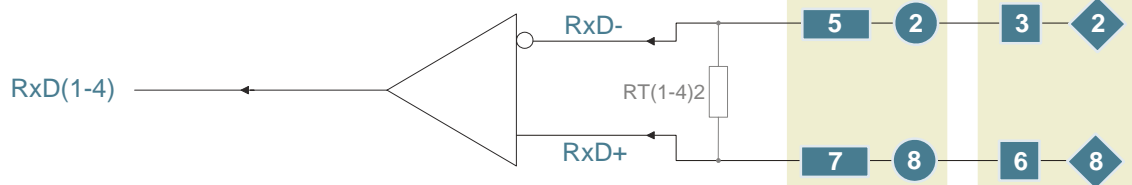

For differential RS-485 terminations, resistors are required at

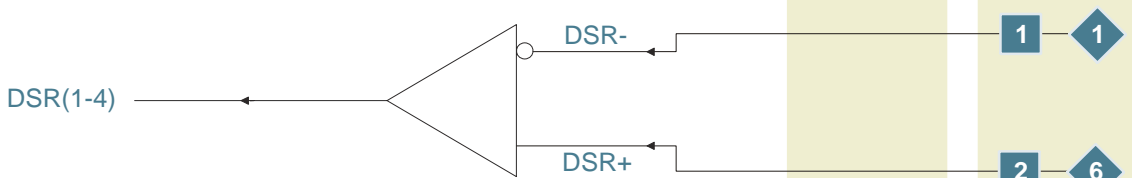

different RS-lines resistors are required both

ends of the signal bus (120 Ohms typically). These resistors are normally located outside of the CU4-SOPRANO, e.g. soldered directly onto the DB9 connector pods. As an alternative, RxD and TxD may be terminated on-board (RTxx). Due to a short-circuit condition in RS-232 mode however, internal termination should be selected only if the purpose of the board is RS-485 mode permanently.

Internal Connectors	
P1..P4	Optional 10-position dual-row pin headers, serial interfaces RS-232/RS-485
P5	Optional 26-position dual row pin header, IEEE 1284 compatible parallel port (EPP)

As an alternative to the front panel connectors, the (optional) internal pin rows P1..P4 can be used.

P1	P2	P3	P4 (Option)	Dual-Row Header 2.54mm RS-232
DCD			1	2 DSR
RXD			3	4 RTS
TXD			5	6 CTS
DTR			7	8 RI
GND			9	10 do not use

P1	P2	P3	P4 (Option)	Dual-Row Header 2.54mm RS-485
DSR-			1	2 DSR+
RXD-			3	4 TXD-
TXD+			5	6 RXD+
DTR+			7	8 do not use
GND			9	10 DTR-

red = input blue = output

The P1..P4 pin rows may be used for attachment of a flat cable assembly with a D-Sub connector. In contrast to the RJ1..RJ4 jacks, the modem signal RI (RS-232 Ring Indicator) is supported in this configuration. Furthermore, when RS-485 mode is selected, in addition to the RxD/TxD data transmission lines also the DSR/DTR handshake signals are available across the P1..P4 connectors.

When preparing a suitable micro ribbon flat cable assembly, be sure that pin 1 of the row header matches pin 1 of the DB9 connector (use marked side of the flat cable). Cable assemblies are also available ready to use by EKF. The schemes below show the resulting signal assignment for both RS-232 and RS-485.

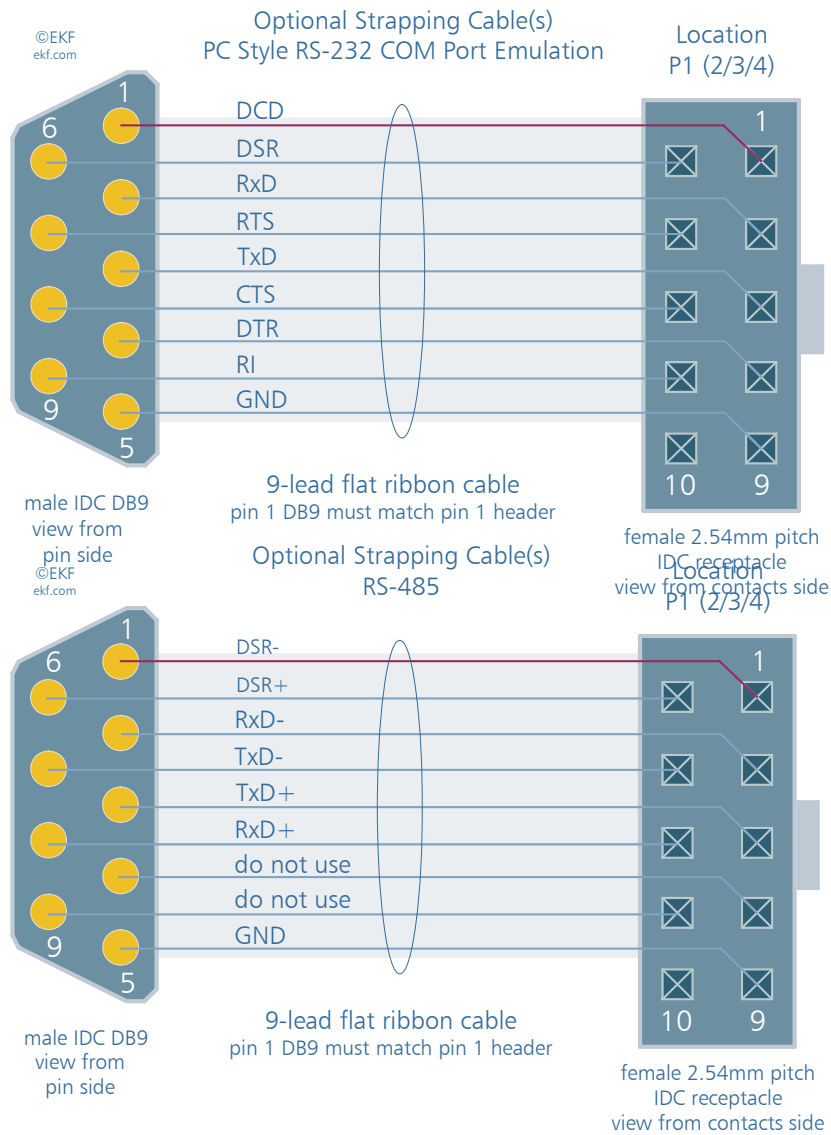

As an option, the CU4-SOPRANO can be equipped with the dual-row pin header P5, which may be used as a parallel port.

P5 (Option) Dual-Row Header 2.54mm			
STB#	1	2	AFD#
PD0	3	4	ERR#
PD1	5	6	INIT#
PD2	7	8	SLIN#
PD3	9	10	GND
PD4	11	12	GND
PD5	13	14	GND
PD6	15	16	GND
PD7	17	18	GND
ACK#	19	20	GND
BUSY	21	22	GND
PE	23	24	GND
SLCT	25	26	

Typically, a flat cable assembly will be used for attachment of a 25-position female D-Sub connector, which then is pin compatible with a desktop LPT port. A suitable cable assembly can be ordered from EKF.

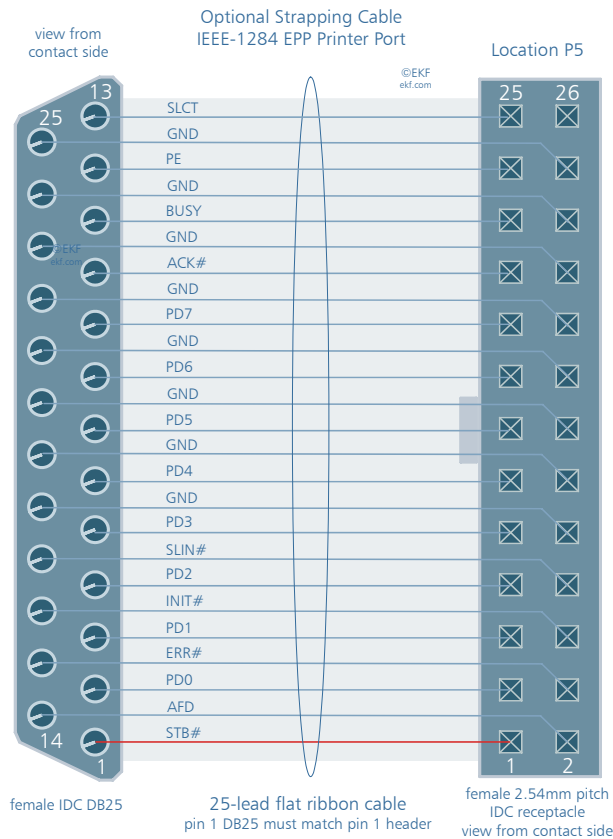

Configuration Jumpers

JSER	Configuration RS-232 or RS-485 individually selectable for each serial port, when in RS-485 mode: drivers enable by RTS low, DTR low or fixed selection
------	---

A jumper set on position JSER 1..4 configures the respective serial interface port transceiver to the RS-485 modus. A jumper removed forces the corresponding transceiver to the RS-232 mode.

Only when in RS-485 mode, the jumper positions JSER 5..6 are significant. Normally both jumpers 5 and 6 are removed. This enables permanently the differential line drivers, which is the suitable condition for the full-duplex transfer mode (also known as point-to-point or 2-point connection, both nodes can simultaneously send and receive data).

If more than two nodes are connected to a common bus, this operation mode is called RS-485 half-duplex (AKA party-line, only one node is allowed to send). The RxD and TxD lines are connected together in the party-line mode. A software protocol is required in order to pass a token to the active node, which sets its status signal RTS or DTR adequately. Jumpers JSER 5/6 are provided to control the behaviour of the RS-485 transmitters, in accordance to the settings in the driver software:

Jumper JSER 5	Jumper JSER 6	RS-485 Drivers
removed	removed	permanently enabled
installed	removed	enabled by RTS
removed	installed	enabled by DTR
installed	installed	permanently disabled

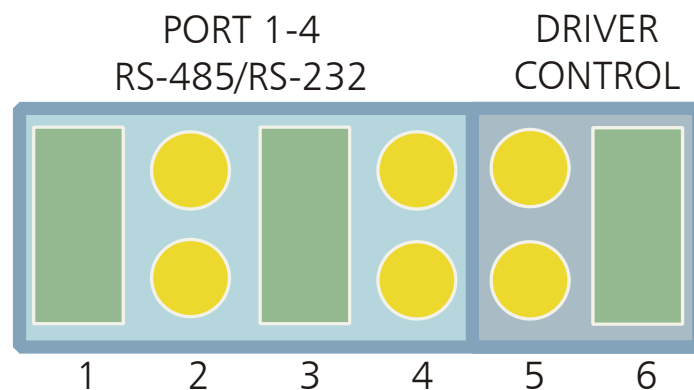

JSER example configuration:

- (1) PORT1 configured as RS-485
- (2) PORT2 configured as RS-232
- (3) PORT3 configured as RS-485
- (4) PORT4 configured as RS-232
- (5/6) RS-485 drivers enabled with DTR=low

©EKF
ekf.com

CompactPCI Connectors

J1	32-Bit CPCI interface
J2	Optional connector, required for rear I/O across transition board CU9-2 and PHY-modules CU7/CU8

#J1	A	B	C	D	E
25	5V	<i>REQ64#</i>	<i>ENUM#</i>	3.3V	5V
24	AD1	5V	VI/O	AD0	<i>ACK64#</i>
23	3.3V	AD4	AD3	5V	AD2
22	AD7	GND	3.3V	AD6	AD5
21	3.3V	AD9	AD8	M66EN	C/BE0#
20	AD12	GND	VI/O	AD11	AD10
19	3.3V	AD15	AD14	GND	AD13
18	SERR#	GND	3.3V	PAR	C/BE1#
17	3.3V	<i>IPMB SCL</i>	<i>IPMB SDA</i>	GND	PERR#
16	DEVSEL#	GND	VI/O	STOP#	LOCK#
15	3.3V	FRAME#	IRDY#	BD SEL#	TRDY#
14					
13			Blue +5V Key		
12					
11	AD18	AD17	AD16	GND	C/BE2#
10	AD21	GND	3.3V	AD20	AD19
9	C/BE3#	IDSEL	AD23	GND	AD22
8	AD26	GND	VI/O	AD25	AD24
7	AD30	AD29	AD28	GND	AD27
6	REQ#	GND	3.3V	CLK	AD31
5	<i>BRSVP1A5</i>	<i>BRSVP1B5</i>	RST#	GND	GNT#
4	<i>IPMB PWR</i>	HEALTHY#	VI/O	<i>INTP</i>	<i>INTS</i>
3	INTA#	INTB#	<i>INTC#</i>	5V	<i>INTD#</i>
2	<i>TCK</i>	5V	<i>TMS</i>	<i>TDO</i>	<i>TDI</i>
1	5V	-12V	<i>TRST#</i>	+12V	5V

Pin positions printed italic/gray: Not connected

The rear I/O connector J2 is stuffed as an option only. In order to avoid potential conflicts, before installing the CU4-SOPRANO with the J2 populated, ensure that the system is not equipped with a P2 CompactPCI 64-bit expansion backplane. Otherwise, permanent damage to the board or to system components could occur.

#J2	A	B	C	D	E
22					
21					
20					
19					
18					
17					
16					
15					
14					
13					
12					
11					
10					
9					
8	DSR1#	RXD1	DTR1#	CTS1#	GND
7	+5V	RI1#	TXD1	RTS1#	DCD1#
6	DSR2#	RXD2	DTR2#	CTS2#	GND
5	+5V	RI2#	TXD2	RTS2#	DCD2#
4	DSR3#	RXD3	DTR3#	CTS3#	GND
3	+5V	RI3#	TXD3	RTS3#	DCD3#
2	DSR4#	RXD4	DTR4#	CTS4#	GND
1	+5V	RI4#	TXD4	RTS4#	DCD4#

The signal assignment of the optional J2 connector matches the transition board CU9-2-BASE. Across the transition board, rear I/O PHY-modules of the CU7/CU8 series may be attached by means of a flat cable. For systems with a P2 64-bit CompactPCI expansion backplane, the connector J2 on the CU4-SOPRANO must not be stuffed!



CU9-2-BASE with PHY Modules

The TTL signals from J2/P2 are routed across the rear I/O transition board CU9-2-BASE to its shrouded pin headers H13..H16. By means of a short flat ribbon cable, the PHY modules CU7-RS485 or CU8-RS232 are attached. Up to four PHY modules CU7 and CU8 can be mounted at the 3U/12HP back panel of the CU9-2-BASE. Custom specific rear panels are also available.



CU9-2-BASE Alternate View

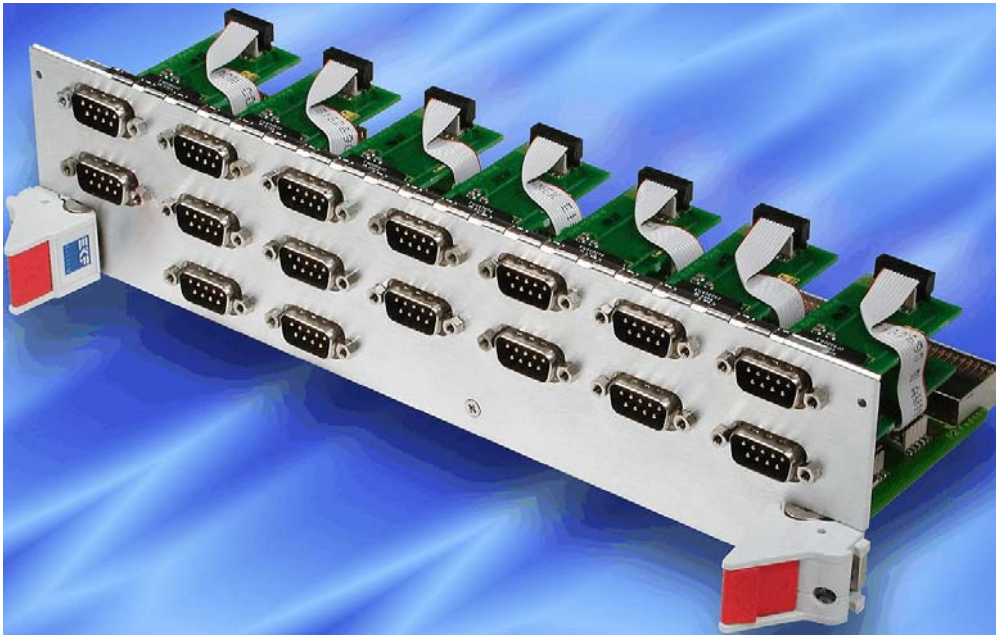

Custom Specific Back Panel 6U



CU7-RS485 PHY Module



CU8-RS232 PHY Module

Available as a special version CU4-P-SOPRANO, the board is provided with a front panel printer port connector. This board version is not equipped with serial I/F transceivers and connectors, and hence is suitable solely as legacy parallel LPT port, aka Centronics printer I/F.

The parallel port complies with the IEEE-1284 EPP parallel port standard. Drivers for Microsoft® Windows® are available by download.



CU4-P-SOPRANO (LPT Parallel Port)

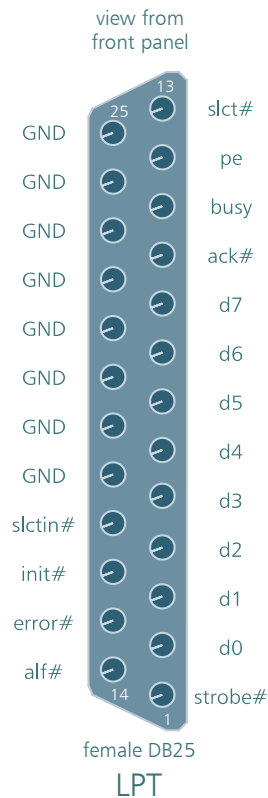

LPT Parallel Port Female D-Sub 25			
STB#	1		
		14	AFD#
PD0	2		
		15	ERR#
PD1	3		
		16	INIT#
PD2	4		
		17	SLIN#
PD3	5		
		18	GND
PD4	6		
		19	GND
PD5	7		
		20	GND
PD6	8		
		21	GND
PD7	9		
		22	GND
ACK#	10		
		23	GND
BUSY	11		
		24	GND
PE	12		
		25	GND
SLCT	13		

Ordering Information		
Alias	Ordering Number	Short Description
SOPRANO	CU4-1-SOPRANO	3U, <i>CompactPCI</i> quad serial interface, configurable alternatively as RS-232 or RS-485 (individually selectable by jumper), serial port connectors mounted in the front panel, w/o J2 connector, suitable for front panel I/O
SOPRANO	CU4-2-SOPRANO	Similar to CU4-1-SOPRANO, with J2 connector, suitable for rear I/O (J2 rear I/O backplane required)
SOPRANO	CU4-P-SOPRANO	Special version of the board, front panel LPT printer parallel port, no serial I/F available
ADAPT	CR9-5-ADAPT	Front panel 6U expansion adapter, mounting kit
	CU7-1-RS485	RS-485/RS-422 rear I/O PHY module, 1 Port, 2.5Mbps, 2-wire half-duplex (party line network), optically isolated, including flat cable assembly
	CU7-2-RS485	RS-485/RS-422 rear I/O PHY module, 1 Port, 2 x 2.5Mbps, 4-wire full-duplex (point to point connection), optically isolated, including flat cable assembly
	CU8-1-RS232	RS-232E rear I/O PHY interface module, including flat cable assembly
	CU9-2-BASE	Transition board, interconnection between CU4-SOPRANO (J2) and rear I/O PHY interface modules, 4 ports, 3U/12HP back panel included (custom specific back panels on request)
	261.92.009.01	Adapter, RJ45 jack to male D-Sub connector 9-pos., customer configurable, suitable e.g. for COM-port emulation
	261.91.009.01	Adapter, RJ45 jack to female D-Sub connector 9-pos., customer configurable, suitable e.g. for null-modem emulation



EKF Elektronik GmbH
Philipp-Reis-Str. 4
59065 HAMM
Germany



Fax. +49 (0)2381/6890-90
Tel. +49 (0)2381/6890-0
Internet www.ekf.com
E-Mail info@ekf.de