

InnoDisk USB EDC horizontal

USB EDC horizontal Datasheet Rev 2.1

Table of contents

REVISION HISTORY	3
List of Tables	4
List of Figures	5
1. Introduction.....	6
2. Features.....	6
3. Pin Assignment.....	7
4. Specifications	7
4.1 CE and FCC Compatibility	7
4.2 RoHS Compliance	7
5. Environmental Specifications	8
5.1 Temperature Ranges.....	8
5.2 Humidity.....	8
5.3 Shock and Vibration.....	8
5.4 Mean Time between Failures (MTBF)	8
5.5 Mechanical Dimensions.....	9
5.6 Electrical Specifications	10
5.6.1 Absolute Maximum Ratings.....	10
5.6.2 Operating Conditions.....	10
5.6.3 DC Characteristic	10

REVISION HISTORY

Revision	Description	Date
1.0	First Release	March 2007
1.1	Modify some information	April 2007
1.2	Remove vertical type I	November 2007
1.3	Correct pin assignment	March 2008
1.4	Modify some information	March 2008
1.5	Modify storage temperature	April 2008
1.6	Updated OS bootable support and clarify type (vertical and horizontal)	June 2008
1.7	Add power supply 3.3V and 1.8V	June 2008
1.8	Remove power supply 1.8V	July 2008
1.9	Modify operating temperature	Aug 2008
2.0	Wording correction	Dec 2009
2.1	Remove 128, 256 MB	July 2010

List of Tables

Table 1: USB EDC Horizontal Type Pin Assignments	7
Table 2: Shock/Vibration Testing for USB EDC	8
Table 3: USB EDC MTBF	8
Table 4: USB EDC Absolute Maximum Ratings	10
Table 5: USB EDC Operating Conditions	10
Table 6: USB EDC DC Characteristic	10

List of Figures

Figure 1: Mechanical Dimension of USB EDC Horizontal Type (2.54mm)	9
Figure 2: Mechanical Dimension of USB EDC Horizontal Type (2.00mm)	9

1. Introduction

The InnoDisk USB EDC (Embedded Disk Card) products provide high capacity USB flash memory storage that electrically complies with High-speed USB 2.0 interface & backward compatible with USB 1.1. With vertical and horizontal version for option, the device features attractive small form factor and the connectivity over USB2.0 and the NAND flash architecture provide a faster data transmission.

2. Features

The USB EDC products provide the following system features:

- Capacities: 512MB, 1GB, 2GB, 4GB, and 8GB
- High-speed USB 2.0 interface; backward compatible with USB 1.1
- Pin-pitch: 2.00mm and 2.54 mm
- High reliability based on the internal 4bit ECC (Error Correction Code) function
- Read & Write performance: (maximum speed)
 - Horizontal version
 - ◆ 1GB, 2GB, 4GB, 8GB - Read: 32Mbytes/s, Write: 23Mbytes/s
 - ◆ 512MB - Read: 19Mbytes/s, Write: 17Mbytes/s
- Wear-leveling supported
- Two NAND flash interleave supported (Horizontal version: 1, 2, 4, and 8GB)
- Low power consumption
 - Power supply: 5V and 3.3V
 - Read/Write: 120mA (max.)
- Embedded XP Evaluation, Build 2600.XPSP1. 020828-1920 (boot-up support)
- Fixed/Removable mode (for option, default is Fixed mode)
- Temperature range:
 - Operating: 0°C ~ +70°C (Standard grade)
-40°C~ +85°C (Industrial grade)
 - Storage: -55°C ~ +95°C

3. Pin Assignment

See Table 1 for USB EDC horizontal type pin assignments.

Table 1: USB EDC Horizontal Type Pin Assignments

Horizontal Type			
Pin No.	Signal	Pin No.	Signal
1	+5VDC	2	NC
3	USB Data(-)	4	NC
5	USB Data(+)	6	NC
7	GND	8	NC
9	NC	10	NC

4. Specifications

4.1 CE and FCC Compatibility

The InnoDisk USB EDC conforms to CE requirements and FCC standards.

4.2 RoHS Compliance

The InnoDisk USB EDC is fully compliant with RoHS directive.

5. Environmental Specifications

5.1 Temperature Ranges

Operating Temperature Range: 0°C to +70°C

Storage Temperature Range: -55°C to +95°C

5.2 Humidity

Relative Humidity: 10-95%, non-condensing.

5.3 Shock and Vibration

Table 2: Shock/Vibration Testing for USB EDC

Reliability	Test Conditions	Reference Standards
Vibration	10 Hz to 500 Hz, 5 g, 3 axes, 1hour	IEC 68-2-6
Mechanical Shock	Duration: 10ms, 50 g, 3 axes, 20times	IEC 68-2-27

5.4 Mean Time between Failures (MTBF)

Table 2 summarizes the MTBF prediction results for various USB EDC configurations. The analysis was performed using a RAM Commander™ failure rate prediction.

- **Failure Rate:** The total number of failures within an item population, divided by the total number of life units expended by that population, during a particular measurement interval under stated condition.
- **Mean Time between Failures (MTBF):** A basic measure of reliability for repairable items: The mean number of life units during which all parts of the item perform within their specified limits, during a particular measurement interval under stated conditions.

Table 3: USB EDC MTBF

Product	Condition	MTBF (Hours)
Horizontal Version	Telcordia SR-332 GB, 25°C	> 3,000,000

5.5 Mechanical Dimensions

Horizontal Type: (2.54mm) 37.8/26.65/8.7 mm (L/W/H)

(2.00mm) 37.8/26.65/5.0 mm (L/W/H)

Figure 1: Mechanical Dimension of USB EDC Horizontal Type (2.54mm)

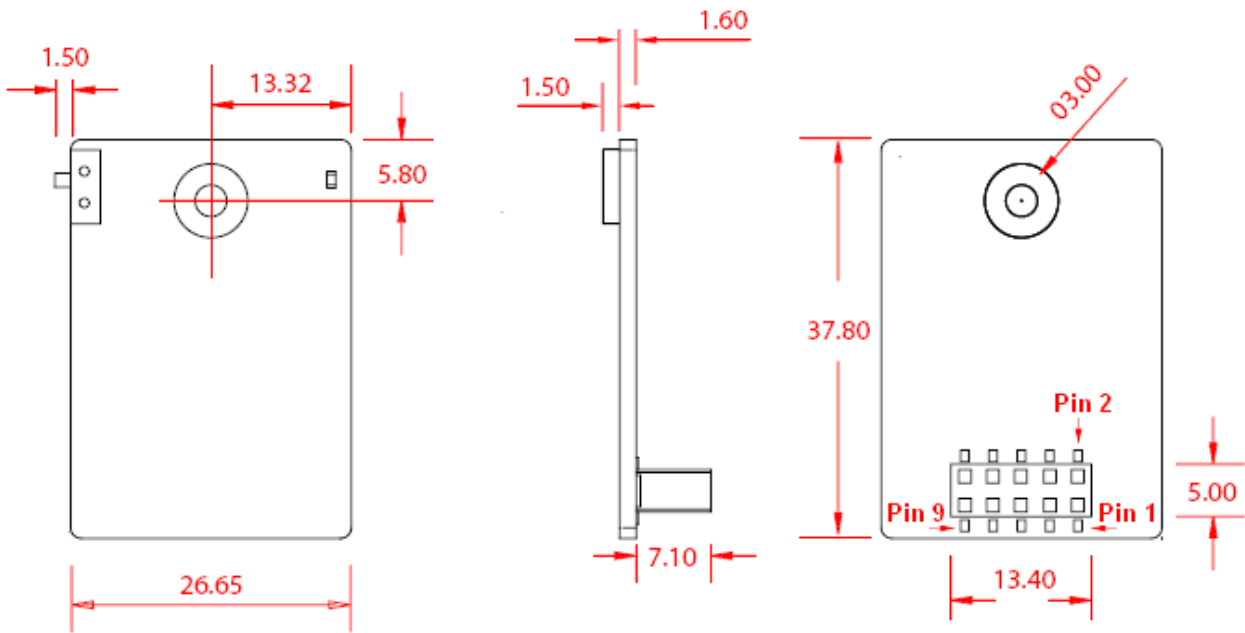
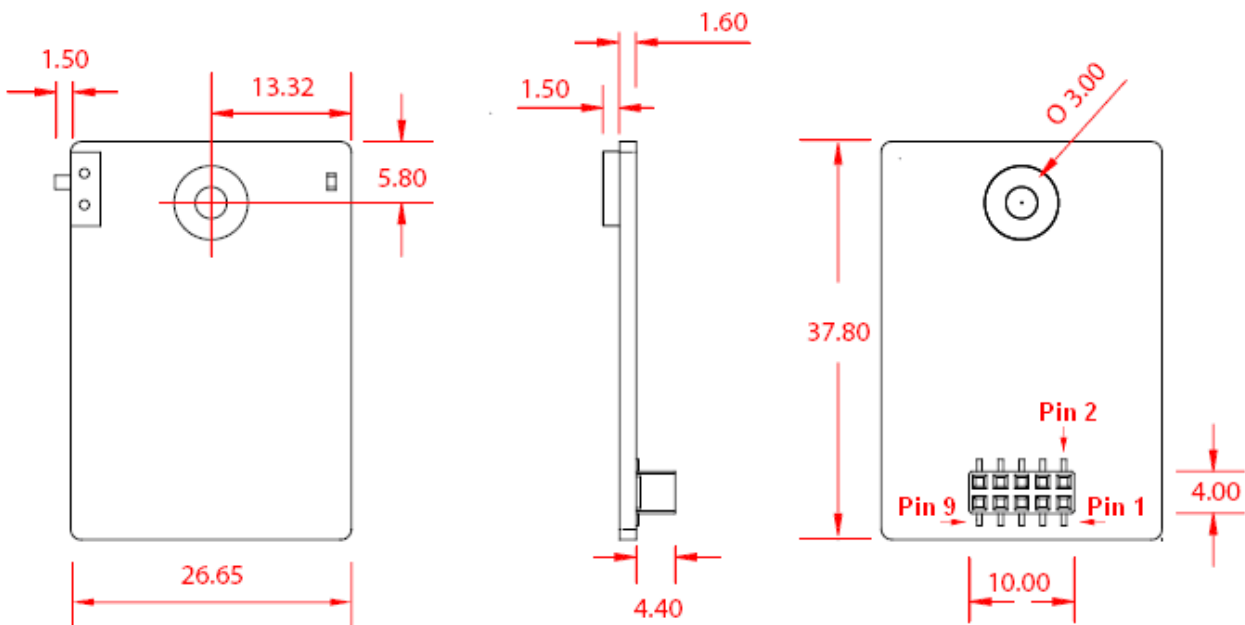

Figure 2: Mechanical Dimension of USB EDC Horizontal Type (2.00mm)



5.6 Electrical Specifications

5.6.1 Absolute Maximum Ratings

Table 4: USB EDC Absolute Maximum Ratings

Item	Symbol	Rating	Unit
Storage Temperature	TStorage	-55 ~ +95	°C
Ambient Operating Temperature	Ta	0 ~ +70	°C
3.3V supply voltage	VCC33	-0.3 ~ 3.6	V
1.8V supply voltage	VCC18	-0.3 ~ 2	V
3.3V buffer input voltage	Vin33	-0.3 ~ 3.6	V
3.3V/5V buffer input voltage	Vin335	-0.3 ~ 5	V
1.8V buffer input voltage	Vin18	-0.3 ~ 2	V

5.6.2 Operating Conditions

Table 5: USB EDC Operating Conditions

Item	Symbol	Rating	Unit
USB 5V supply voltage	USBVin	3.2 ~ 5.5	V
3.3V supply voltage	VDD33	3.0 ~ 3.6	V
1.8V supply voltage	VDD18	1.6 ~ 2	V

5.6.3 DC Characteristic

Table 6: USB EDC DC Characteristic

Item	Symbol	Min	Max	Unit
TTL Input low voltage	VIL_TTL	-0.3	0.8	V
TTL Output high voltage	VOH_TTL	0.9 VCC33		V
TTL Output low voltage	VOL_TTL		0.45	V
TTL Output high current	IOH_TTL	-4		mA
TTL Output low current	IOL_TTL		4	mA
USB Input high voltage for low/full speed	VIH_USB	2.0		V
USB Input low voltage for low/full speed	VIL_USB		0.8	V
Difference common mode input range for low/full speed	VI_USB_CM	0.8	2.5	V
USB high speed squelch input detection threshold	VI_USB_HSSQ	0.1	0.15	V
USB high speed disconnect input detection threshold	VI_USB_HSDSC	0.525	0.625	V

USB high speed signaling common mode range	VI_USB_HSCM	-0.05	0.5	V
USB output high voltage for low/full speed	VOH_USB	2.8	3.6	V
USB output low voltage for low/full speed	VOL_USB	0	0.3	V
USB output high voltage for high speed	VOH_USB_HS	0.36	0.44	V
USB output low voltage for high speed	VOL_USB_HS	-0.01	0.01	V
USB output high current for low/full speed	IOH_USB	-10		mA
USB output low current for low/full speed	IOL_USB		10	mA
USB output high current for high speed	IOH_USB_HS	-40		mA
USB output low current for high speed	IOL_USB_HS		40	mA