

LED *Backlight Solutions*



Backlight Management • Backlight Management

Microsemi's new families of LED Backlight Controllers are designed to provide superior performance and functionality in demanding LCD TV, notebook computers, automotive and other display platforms and applications. The third-generation Digital Advanced Zone Lighting (DAZL™) architecture used in these families includes Microsemi's PureBLACK™ mega-contrast dimming technology, which improves PWM-dimming duty-cycle performance in edge-lit LED displays.

Pure **BLACK™**



Microsemi has pioneered a dimming approach called “Adaptive Local Dimming”, which enables the backlight circuitry to light only the image areas that need to be lit, and dim the black areas, resulting in blacker blacks and significantly improved color, contrast, motion sharpness and grey level, plus associated power savings from eliminating unnecessary backlighting.

Selection Guide

Consult **NEW** Factory

Part Number Package	Description	Type	# of LEDs	Input Voltage (VDC)	Output Voltage (VDC)	Output Current (mA)	Applications
LX24132 8x8mm - QFN56	32 port display backlight Local Dimming (2D) LED controller (LX24132) and 8 port LED driver (LX23108L) chipset.	Chipset with LED controller + FET array drivers	Up to 32 strings and up to 18 LEDs per string	Vcc = 5V VIO = 3.3V or 5V	Up to 72 V per LED string	70mA - typ (100%DC) 140mA - typ (50%DC) 100mA - max (100%DC) 200mA - max (50%DC)	Local dimming TVs and monitors, RGB displays
LX23108L 5x5mm - QFN32							
LX23224 6x6mm - QFN36 SSOP-48	LED driver with integrated DC-DC controller to support a total of 4 LED strings.	LED driver with external high voltage MOSFETS	Up to 120 LEDs per string	12V-250V	Up to 400V	Up to 250mA	D0 edge LED BL architecture
LX23214 7x7mm - QFN48 SSOP-48	LED driver with 2 integrated independent DC-DC controllers to support a total of 4 LED strings with 2 strings per DC-DC section.	LED driver with external high voltage MOSFETS	Up to 120 LEDs per string	12V-250V	Up to 400V	Up to 250mA	D0 edge LED BL architecture
LX23203 7x7mm - QFN48 SSOP-48	LED driver with 3 integrated and fully independent DC-DC controllers to support 3 LED strings with 1 string per DC/DC section.	Non-dissipative LED driver with no LED binning requirements and external high voltage MOSFETS.	Up to 120 LEDs per string	12V-250V	Up to 400V	Up to 350mA	D0 and D1 edge LED BL architecture
LX1996 MLP-6	Integrated LED driver, up to 6 parallel strings with multi-mode dimming and panel temperature compensated LED current.	Switching boost converter with six precision constant current sources with internal FETs up to 25kHz PWM	>60	2.7V - 5.5V	40V	up to 30mA per string	Large LCD panels (notebook size displays)
LX1995-2 MLPQ-16	Integrated LED driver high efficiency and low quiescent current.	Switching boost converter with constant current source with internal FET	up to 5 x 2	4.5V - 5.5V	30V	up to 150mA	Small LCD backlight panels
LX1994 MSOP-8 MLP-8	High efficiency LED driver with OVP	Switching boost converter with external N-FET, Light Sensor and PWM interface	up to 14	1.6V - 6V	60V	up to 150mA	Large LCD panels for portable applications
LX1991 MSOP-10 MLP-10	LED display driver with precision current control and dual-mode dimming	6 channel current sink with LED driver	up to 60	1.6V to 6V Startup 1.6V	40V	up to 30mA per string	Large LCD panels for portable applications

CHIPSET SOLUTION FOR LED BACKLIT TVs

LX23108L™ 8 PORT LED DRIVER

- Excellent thermal performance.
- High current accuracy: $\pm 2\%$ for chipset (LX24132 and LX23108L)
- Driving capability (constant current sink) 0mA to 100mA @ 100% PWM, or 200mA @ 50% PWM
- Per channel PWM signal
- Open string, short LED and over-temperature protection
- 32 pin, 5mm x 5mm QFN package

LX24132™ 32 PORT LED Controller

- Up to 32 LED strings with $\pm 1.5\%$ precision current matching
- Wide dimming ratio with PWM and LED current amplitude control
- 12-bit PWM duty-cycle resolution and 8-bit resolution for LED current setting
- LED power supply voltage control
- SPI communication interface
- Open string, short LED and over-temperature protection
- 56 pin, 8mm x 8mm QFN package

Adaptive Local Dimming

Our Adaptive Local Dimming approach is implemented in Microsemi's LX24132 32-port LED backlight controller and LX23108L 8-port LED driver, which provide scalable, integrated solutions for direct or edge-lit backlight applications in either White LED or RGB LED implementations of flat-panel LCD TV displays. The chipset can easily be integrated with Microsemi's complementary light sensor and color management system solutions to deliver additional quality and functionality.

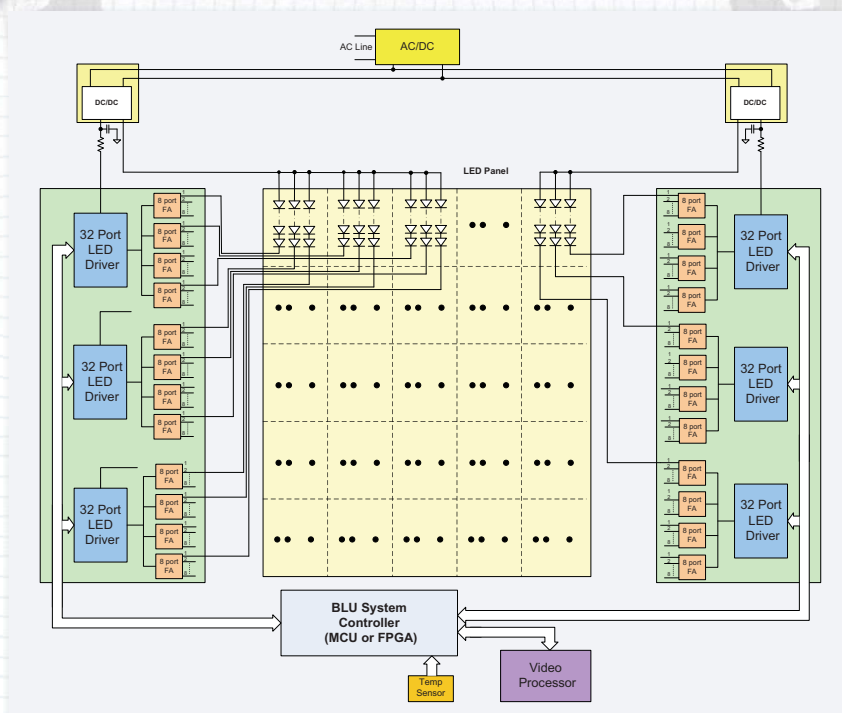

LED Backlight Controllers

Microsemi's Family of LED backlight controllers is designed for ultra-thin edge-lit LCD TV displays. This new family is our third generation of DAZL™ (Digital Advanced Zone Lighting) products and continues to address the system-level cost and performance issues facing the industry. The products incorporate our PureBLACK™ technology and provide options to support both analog and digital PWM dimming frequencies to 2kHz.



ultra thin

LX23203™

- 1 to 3 PWM input
- Non dissipative
- Per String DC-DC 40-200Vo LED Current Up 350mA
- Does not require LED binning provide low power dissipation
- Two IC can be cascaded for 6 string solution
- Analog and digital dimming signals
- Supporting 1D-3D solutions.
- LED short & OVL protection
- Samples Q3/10

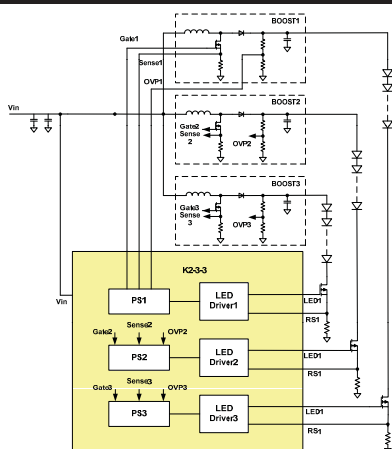

LX23214™

- 1 to 2 PWM input
- Cost effective 4 strings quasi "non dissipative"
- 2 DC-DC controllers for 4 strings. 40-200Vo
- LED current up to 250mA
- Suitable to support 3D solutions
- Analog and digital dimming signals
- Optional Smart Vsync support
- LED Short & OVL protection
- Samples available now.

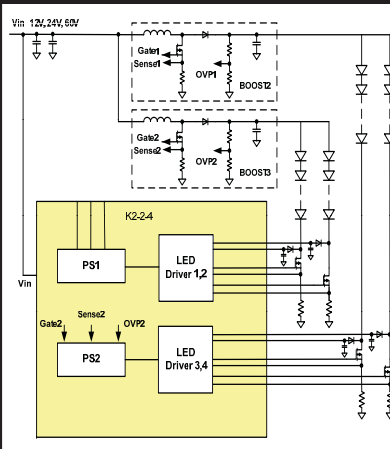

LX23224™

- 1 to 2 PWM input
- Cost effective 4 strings quasi "non dissipative"
- 1 DC-DC controllers for 4 strings. 40-200Vo
- LED current up to 250mA
- Suitable to support 3D solutions
- Analog and digital dimming signals
- Smart Vsync support
- LED Short & OVL protection
- Samples Q1/11

