

**DESCRIPTION**

NX7102 is a 340kHz fixed frequency, current mode, PWM synchronous buck (step-down) DC-DC converter, capable of driving a 3A load with high efficiency, excellent line and load regulation. The device integrates N-channel power MOSFET switches with low on-resistance. Current mode control provides fast transient response and cycle-by-cycle current limit.

The controller is equipped with output over-voltage protection which protects the IC under an open load condition. Additional safety features include under voltage lock-out (UVLO), programmable soft-start and over-temperature protection (OTP) to protect the circuit.

This IC is available in SOIC-8 with exposed pad package.

**KEY FEATURES**

- 3A Synchronous Step-down Regulator
- Operational Input Supply Voltage Range: 4.75V-18V
- Integrated Upper NMOS and Lower NMOS
- 340kHz Switching Frequency
- Input UVLO
- Enable
- Programmable External Soft-Start
- Cycle-By-Cycle Over-Current Protection
- Over Voltage Protection
- Frequency Fold Back Under Short Condition

**APPLICATIONS**

- Set-Top Box
- LCD TV's
- Notebook/Netbook
- PoE Powered Devices

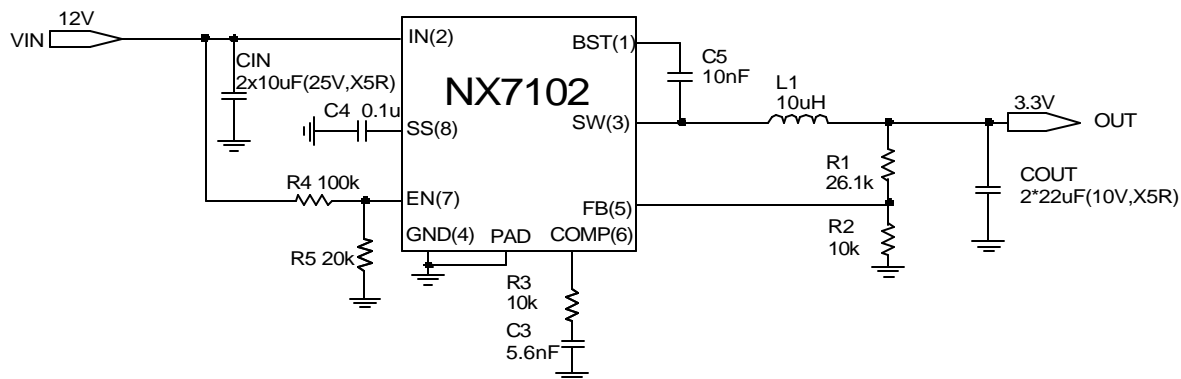
**PRODUCT HIGHLIGHT**


Figure 1 – 12V Input, 3.3V Output with Ceramic Cap

**PACKAGE ORDER INFO**

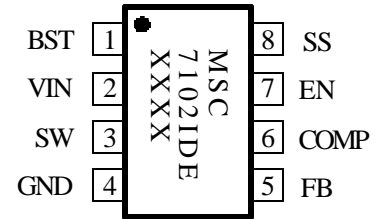
T <sub>A</sub> (°C)	<b>DE</b>	Plastic SOIC 8 Pin
		With Exposed Pad
		RoHS Compliant / Pb-free
-40 to 85		<b>NX7102IDE</b>

Note: Available in Tape & Reel. Append the letters "TR" to the part number. (i.e. NX7102IDE-TR)

**ABSOLUTE MAXIMUM RATINGS**

Supply Input Voltage (VIN).....	-0.3V to 20V
Switch Voltage (SW).....	-1V to (VIN + 1V)
EN .....	-0.3V to (VIN + 0.3V)
BST .....	-0.3V to (VSW + 6V)
COMP, FB, SS .....	-0.3V to 6V
Maximum Operating Junction Temperature .....	150°C
Storage Temperature Range .....	-25°C to 150°C
Package Peak Temp. for Solder Reflow (40 seconds maximum exposure).....	260°C

Note: Exceeding these ratings could cause damage to the device. All voltages are with respect to Ground. Currents are positive into, negative out of specified terminal.

**PACKAGE PIN OUT**


DE PACKAGE  
(Top View)

**DE PART MARKING**

"xxxx" Denote Date Code and Lot Identification

RoHS / Pb-free 100% Matte Tin Pin Finish

**THERMAL DATA**
**DE Plastic SOIC 8-Pin With Exposed Pad**

<b>THERMAL RESISTANCE-JUNCTION TO AMBIENT, <math>\theta_{JA}</math></b>	<b>75° C/W</b>
---	----------------

Junction Temperature Calculation:  $T_J = T_A + (P_D \times \theta_{JA})$ .

The  $\theta_{JA}$  numbers are guidelines for the thermal performance of the device/pc-board system. All of the above assume no ambient airflow.

**FUNCTIONAL PIN DESCRIPTION**

Pin	Name	Description
1	BST	Bootstrap pin. A minimum 10nF bootstrap capacitor is connected between the BS pin and SW pin. The voltage across the bootstrap capacitor drives the internal high side NMOS.
2	VIN	Supply input pin. A capacitor should be connected between the IN pin and GND pin to keep the input voltage constant.
3	SW	Power switch output pin. This pin is connected to the inductor and bootstrap capacitor.
4	GND	Ground.
5	FB	Feedback pin. This pin is connected to an external resistor divider to program the system output voltage. When the FB pin voltage exceeds 20% of the nominal regulation value of 0.925V, the over voltage protection is triggered. When the FB pin voltage is below 0.3V, the oscillator frequency is lowered to realize short circuit protection.
6	COMP	Compensation pin. This pin is the output of the transconductance error amplifier and the input to the current comparator. It is used to compensate the control loop. Connect a series RC network from this pin to GND. In some cases, an additional capacitor from this pin to GND pin is required.
7	EN	Control input pin. Forcing this pin above 1.5V enables the IC. Forcing this pin below 0.4V shuts down the IC. When the IC is in shutdown mode, all functions are disabled to decrease the supply current below 1 $\mu$ A.
8	SS	Soft-start control input pin. SS controls the soft start period. Connect a capacitor from SS to GND to set the soft-start period. A 0.1 $\mu$ F capacitor sets the soft-start period to 9ms. To disable the soft-start feature, leave SS unconnected.

**RECOMMENDED OPERATING CONDITIONS**

Parameter	Symbol	NX7102			Units
		Min	Typ	Max	
Input Operating Voltage	$V_{IN}$	4.75		18	V
Maximum Output Current	$I_{OUTMAX}$	3			A
Operating Ambient Temperature	$T_A$	-40		85	°C

**ELECTRICAL CHARACTERISTICS**

Unless otherwise specified, the following specifications apply for  $V_{IN} = V_{EN} = 12V$ ,  $V_{OUT} = 5V$ ,  $T_A = 25^\circ C$ .

Parameter	Symbol	Test Conditions	NX7102			Units
			Min	Typ	Max	
<b>Operating Current</b>						
Quiescent Current	$I_Q$	$V_{FB} = 1V$	0.8	1.0	1.2	mA
Shutdown Current	$I_{SHDN}$	$V_{EN} = 0V$		1	10	$\mu A$
<b>UVLO</b>						
$V_{IN}$ UVLO Threshold	$V_{UVLO}$	$V_{IN}$ Rising	3.65	4.05	4.45	V
Hysteresis Frequency	$V_{HYS}$			0.2		V
<b>Feedback</b>						
Feedback Voltage	$V_{FB}$		0.900	0.925	0.950	V
Feedback Bias Current	$I_{FB}$	$V_{FB} = 1V$	-0.1		0.1	$\mu A$
<b>Oscillator</b>						
Internal Oscillator Frequency	$F_{OSC1}$		300	340	380	kHz
Short Circuit Oscillator Frequency	$F_{OSC2}$		65	90	115	kHz
Maximum Duty Cycle	$D_{MAX}$	$V_{FB} = 0.8V$	83	90	97	%
Minimum Duty Cycle	$D_{MIN}$	$V_{FB} = 1V$			0	%
Minimum On Time <sup>(1)</sup>	$T_{ON}$			180		ns
<b>Error Amplifier</b>						
Error Amplifier Transconductance	$G_{EA}$		540	800	1060	$\mu A/V$
Voltage Gain <sup>(1)</sup>	$A_{EA}$			560		V/V
<b>Current Sensing Gain</b>						
Current Sensing Gain	$G_{CS}$		4	5.2	6.4	A/V
<b>Soft-Start</b>						
Soft-start Current				6		$\mu A$
Soft-start Time	$T_{SS}$	$C_{SS} = 0.1\mu F$		9		ms
<b>Output Stage</b>						
High-side Switch On Resistance	$R_{DSONH}$		70	100	130	mohm
Low-side Switch On Resistance	$R_{DSONL}$		60	90	120	mohm
High-side Switch Leakage Current	$I_{LEAKH}$	$V_{IN} = 18V, V_{EN} = 0V, V_{SW} = 0V$		0.1	10	$\mu A$
High-side Switch Current Limit	$I_{LIMH}$		4.3	5.5	6.7	A
Low-side Switch Current Limit	$I_{LIML}$		0.85	1.45	2.05	A
<b>EN</b>						
High Threshold	$V_{ENH}$		1.5			V
Low Threshold	$V_{ENL}$				0.4	V

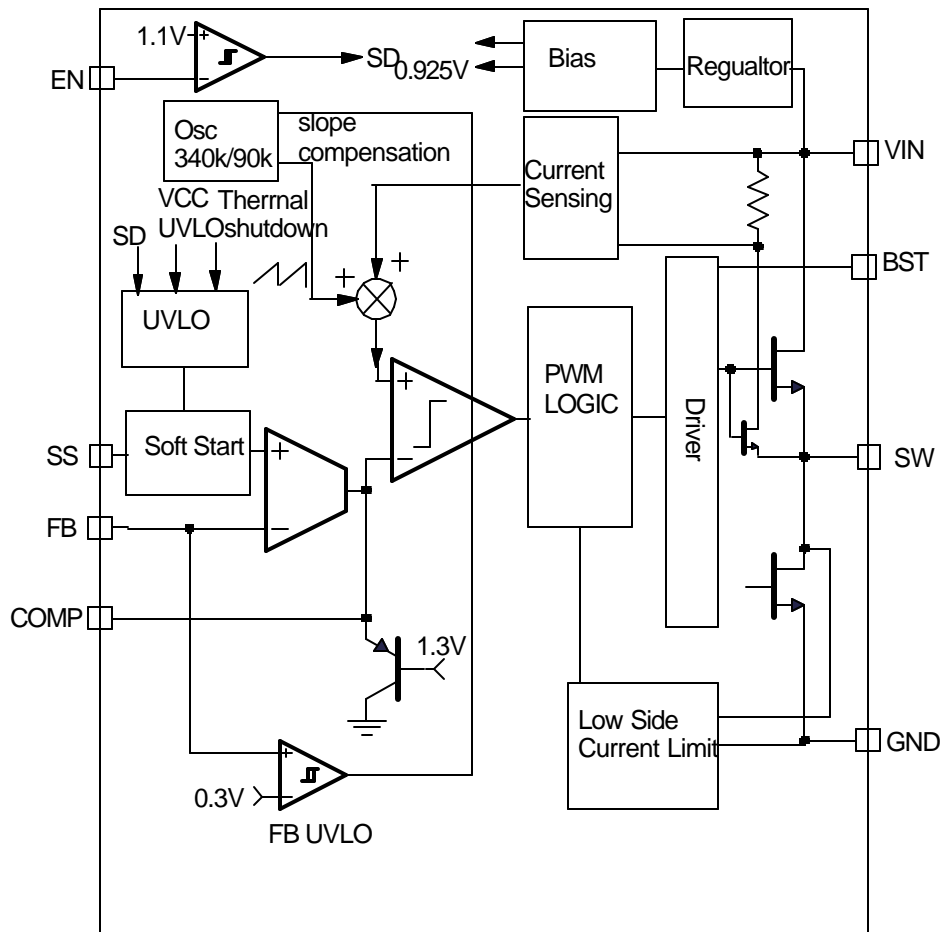
**ELECTRICAL CHARACTERISTICS (CONT)**

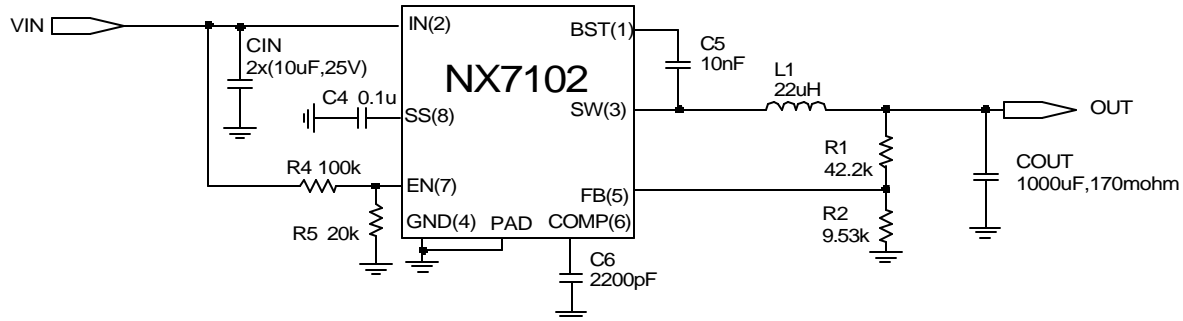
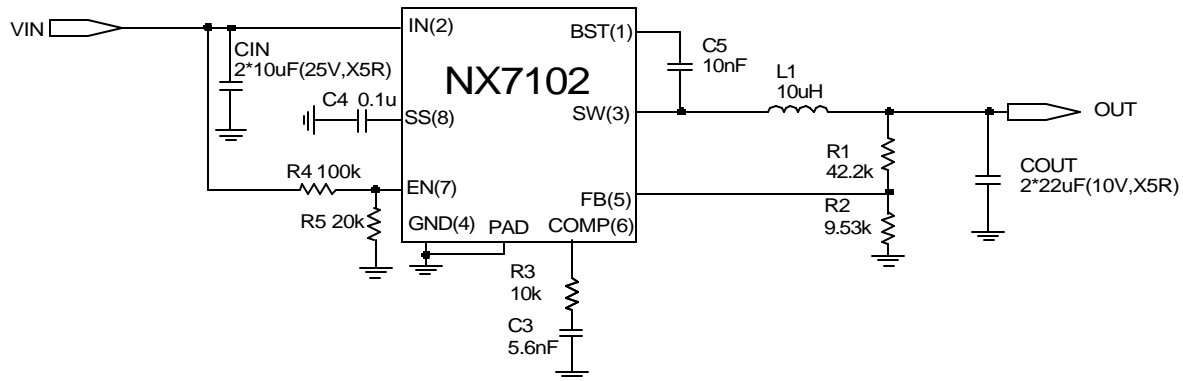
 Unless otherwise specified, the following specifications apply for  $V_{IN} = V_{EN} = 12V$ ,  $V_{OUT} = 5V$ ,  $T_A = 25^\circ C$ .

Parameter	Symbol	Test Conditions	NX7101			Units
			Min	Typ	Max	
<b>Protection</b>						
Over Voltage Protection Threshold	$V_{FBOV}$		1	1.1	1.2	V
FB Short Circuit Protection			0.23	0.3	0.41	V
Thermal Shutdown Threshold	$T_{OTSD}$			160		$^\circ C$
Thermal Shutdown Hysteresis	$T_{HYS}$			30		$^\circ C$

**Notes:**

- 1) Guaranteed by design, not tested.

**SIMPLIFIED BLOCK DIAGRAM**

**Figure 2 – Simplified Block Diagram**

**APPLICATION CIRCUIT**

**Figure 3 – 12V Input, 5V Output with Electrolytic Cap**

**Figure 4 – 12V Input, 5V Output with Ceramic Cap**

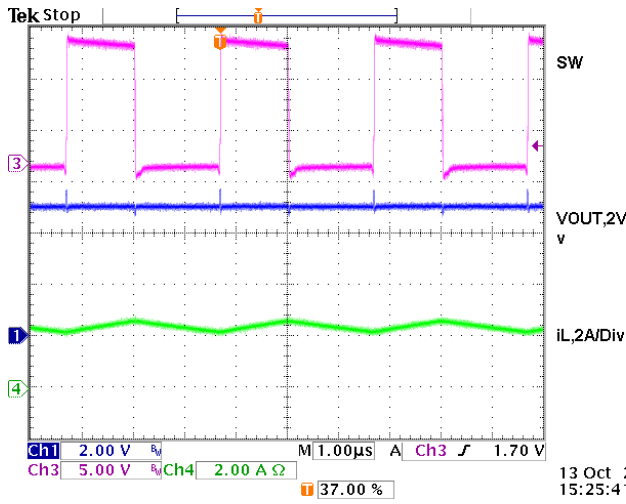
**TYPICAL WAVEFORMS @ 25°C (REFER TO FIGURE 3)**


Figure 5. DC Operation at 3A

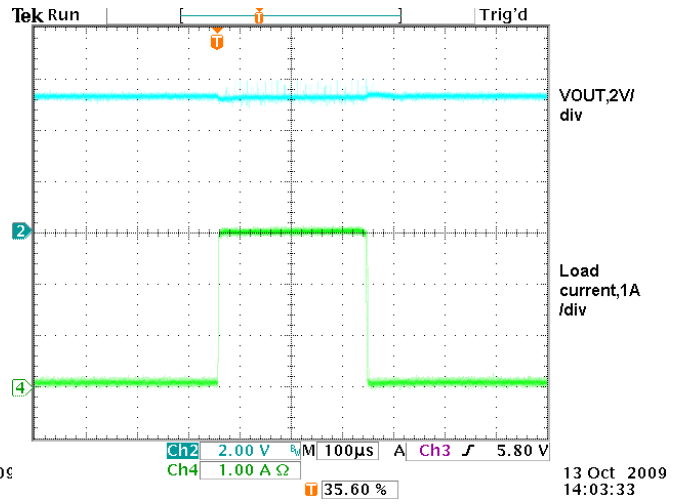


Figure 6. Transient Response

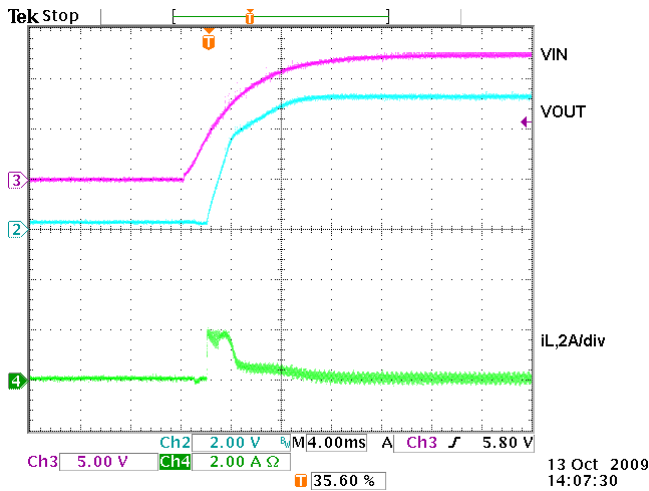


Figure 7. Start up with no load

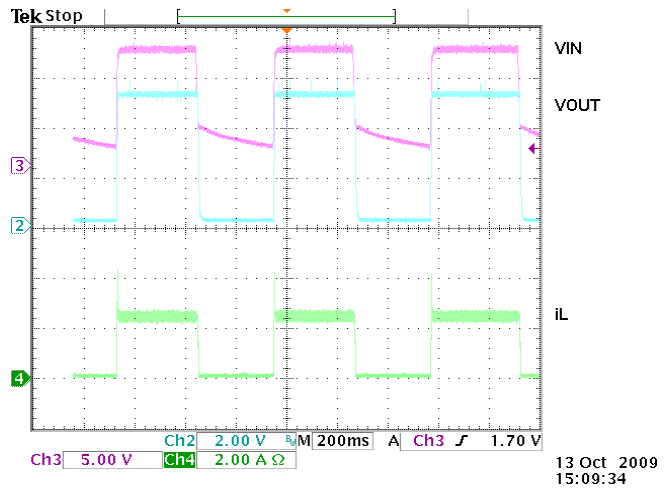


Figure 8. Input power recycling

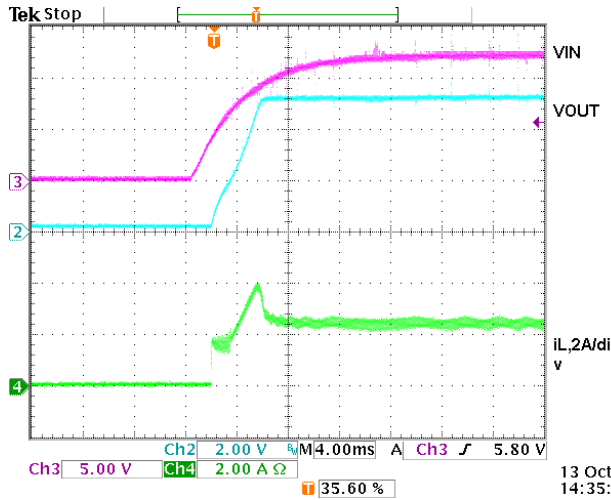
**TYPICAL WAVEFORMS @ 25°C (REFER TO FIGURE 3)**


Figure 9. Start into 2A resistive load

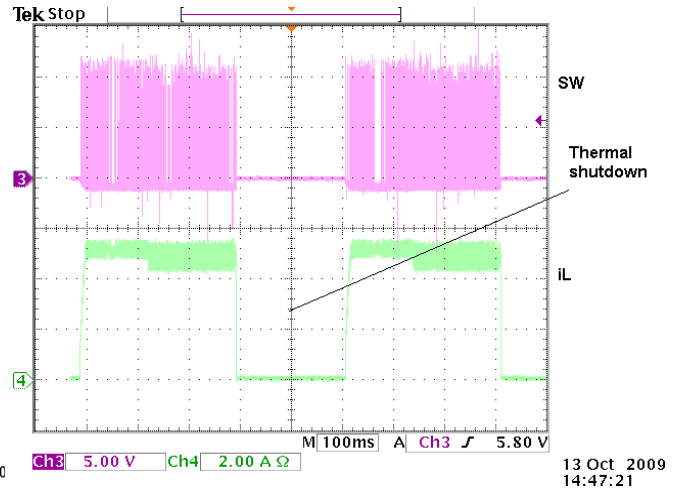


Figure 10. Output short operation

**THEORY OF OPERATION****DETAIL DESCRIPTION**

The NX7102 is a current-mode, PWM synchronous step-down DC-DC converter with 340kHz fixed working frequency. It can convert input voltages from 4.75V to 18V down to an output voltage as low as 0.925V, and supply up to 3A load current.

The NX7102 has two internal N-MOSFET to step down the voltage. The inductor current is determined by sensing the internal high-side MOSFET current. The output of current sense amplifier is summed with the slope compensation signal to avoid subharmonic oscillation at duty cycles greater than 50%. The combined signal is then compared with the error amplifier output to generate the PWM signal.

Current mode control provides not only fast control loop response but also cycle-by-cycle current limit protection. When load current reaches its maximum output level when the inductor peak current triggers high-side NMOFET current limit. If FB pin voltage drops below 0.3V, the working frequency will be fold back to typically 90kHz to protect chip from run-away.

When FB pin voltage exceeds 1.1V, the over voltage protection is triggered. The high side MOSFET is turned off. Once the OVP condition is gone, the chip will resume the operation following soft-start.

The soft-start time is programmable through the SS pin. In order to have desired soft-start time, however when VIN rises very fast, it is necessary to add a resistor divider connected between the VIN and EN pin, so that system will not start until VIN reaches 4V. The typical resistor value on EN pin is shown in figure 4 for VIN=8V application.

**APPLICATION INFORMATION**
**SYMBOL USED IN APPLICATION INFORMATION:**

$V_{IN}$	- Input voltage
$V_{OUT}$	- Output voltage
$I_{OUT}$	- Output current
$\Delta V_{RIPPLE}$	- Output voltage ripple
$F_S$	- Working frequency
$\Delta I_{RIPPLE}$	- Inductor current ripple

**DESIGN EXAMPLE**

The following is typical application for NX7102, the schematic is figure 1.

$$V_{IN} = 12V$$

$$V_{OUT} = 3.3V$$

$$I_{OUT} = 3A$$

**OUTPUT INDUCTOR SELECTION**

The selection of inductor value is based on inductor ripple current, power rating, working frequency and efficiency. A larger inductor value normally means smaller ripple current. However if the inductance is chosen too large, it results in slow response and lower efficiency. Usually the ripple current ranges from 20% to 40% of the output current. This is a design freedom which can be determined by the design engineer according to various application requirements. The inductor value can be calculated by using the following equations:

$$L_{OUT} = \frac{V_{IN} - V_{OUT}}{\Delta I_{RIPPLE}} \times \frac{V_{OUT}}{V_{IN}} \times \frac{1}{F_S}$$

$$I_{RIPPLE} = k \times I_{OUT} \quad \dots (1)$$

where k is between 0.2 to 0.4.

In this design, k is set at 0.23 and 10uH inductor value is chosen. In order to avoid output oscillation at light load, a minimum 8.2uH inductor is required for all NX7102 application.

**OUTPUT CAPACITOR SELECTION**

Output capacitor is basically decided by the amount of the output voltage ripple allowed during steady state(DC) load condition as well as specification for the load transient. The optimum design may require a couple of iterations to satisfy both condition.

The amount of voltage ripple during the DC load condition is determined by equation (2).

$$\Delta V_{RIPPLE} = ESR \times \Delta I_{RIPPLE} + \frac{\Delta I_{RIPPLE}}{8 \times F_S \times C_{OUT}} \quad \dots (2)$$

Where ESR is the output capacitor's equivalent series resistance,  $C_{OUT}$  is the value of output capacitor.

Typically when large value capacitors are selected such as Aluminum Electrolytic, POSCAP and OSCON types are used, the amount of the output voltage ripple is dominated by the first term in equation(2) and the second term can be neglected.

If ceramic capacitors are chosen as output capacitors, both terms in equation (2) need to be evaluated to determine the overall ripple. Usually when this type of capacitor is selected, the amount of capacitance per single unit is not sufficient to meet the transient specification, which results in parallel configuration of multiple capacitors.

In this design two 22uF 6.3V X5R ceramic capacitors are chosen as output capacitors.

**INPUT CAPACITOR SELECTION**

Input capacitors are usually a mix of high frequency ceramic capacitors and bulk capacitors. Ceramic capacitors bypass the high frequency noise, and bulk capacitors supply current to the MOSFETs. Usually 1uF ceramic capacitor is chosen to decouple the high frequency noise. The bulk input capacitors are determined by voltage rating and RMS current rating. The RMS current in the input capacitors can be calculated as:

$$I_{RMS} = I_{OUT} \times \sqrt{D} \times \sqrt{1-D}$$

$$D = \frac{V_{OUT}}{V_{IN}} \quad \dots (3)$$

In this design two 10uF 25V X5R ceramic capacitors are chosen.

**OUTPUT VOLTAGE CALCULATION**

Output voltage is set by reference voltage and external voltage divider. The reference voltage is fixed at 0.925V. The divider consists of two ratioed resistors so that the output voltage applied at the FB pin is 0.925V when the output voltage is at the desired value. The following equation and picture show the relationship between and voltage divider.

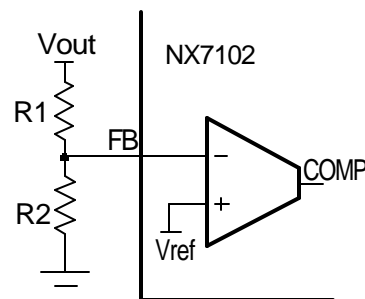


Figure 5 Voltage Divider

**APPLICATION INFORMATION**

$$V_{OUT} = V_{REF} \times \left(1 + \frac{R_1}{R_2}\right) \quad \dots (4)$$

In this design choose R1 26.1kΩ, choose R2 10kΩ.

**COMPENSATOR DESIGN**

The NX7102 uses peak current mode control to provide fast transient and simple compensation. The DC gain of close loop can be estimated by the equation (5).

$$\text{Gain} = A_{EA} \times G_{CS} \times R_{LOAD} \times \frac{V_{FB}}{V_{OUT}} \quad \dots (5)$$

Where  $A_{EA}$  is error amplifier voltage gain 560V/V,  $G_{CS}$  is current sensing gain 5.2A/V,  $R_{LOAD}$  is the load resistor.

The system itself has one pole P1, one zero Z1 and double pole  $P_{DOUBLE}$  at half of switching frequency  $F_S$ .

The system pole P1 is set by output capacitor and output load resistor. The calculation of this pole is given by the equation (6).

$$F_{P1} = \frac{1}{2 \times \pi \times R_L \times C_{OUT}} \quad \dots (6)$$

The system zero Z1 is set by output capacitor and ESR of output capacitor. The calculation of this zero is given by the equation (7).

$$F_{Z1} = \frac{1}{2 \times \pi \times R_{ESR} \times C_{OUT}} \quad \dots (7)$$

The crossover frequency is recommended to be set at  $1/10^{\text{th}}$  of switching frequency. In order to achieve this desired crossover frequency and make system stable, the resistor R3 and the capacitor C3 is needed in typical applications which use ceramic capacitors as output capacitors.

The pole P2 set by output resistance of error amplifier and C3 is given by the equation (8).

$$F_{P2} = \frac{G_{EA}}{2 \times \pi \times A_{EA} \times C_3} \quad \dots (8)$$

Where  $G_{EA}$  is error amplifier transconductance 800uA/V.

The zero Z2 set by R3 and C3 is given by the equation (9).

$$F_{Z2} = \frac{1}{2 \times \pi \times R_3 \times C_3} \quad \dots (9)$$

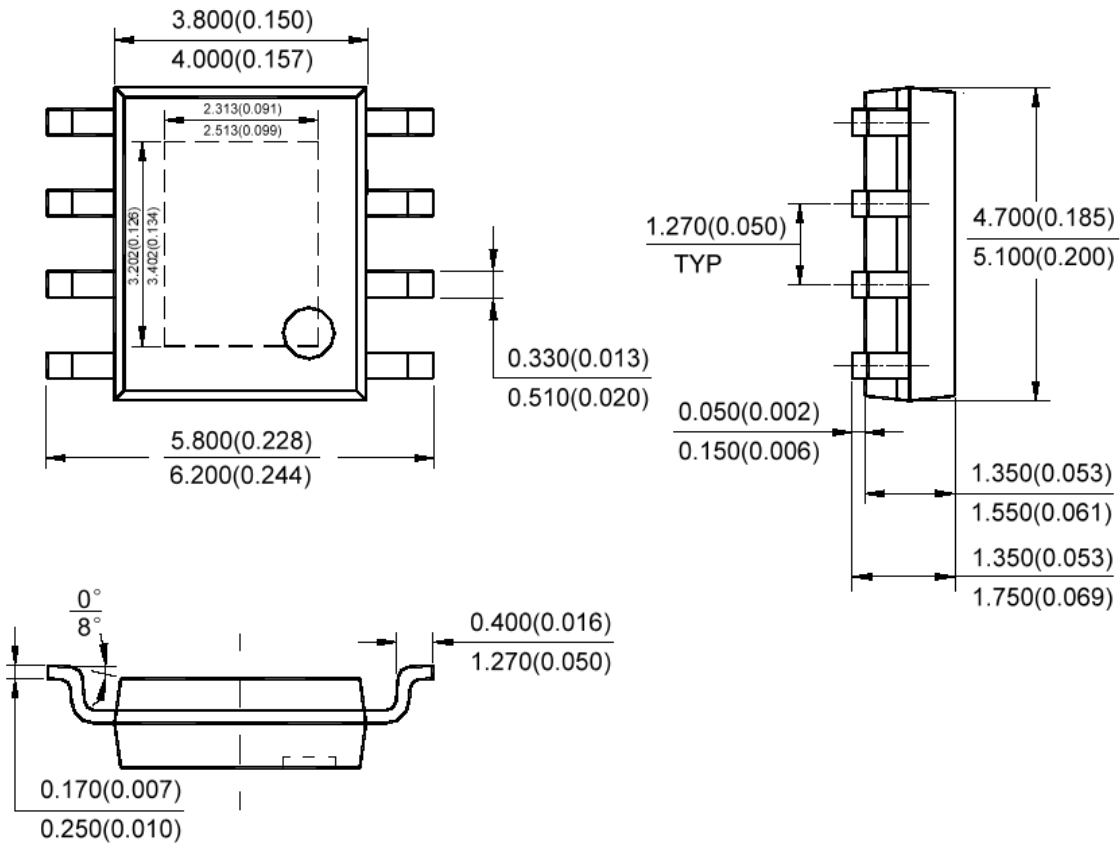
When Aluminum Electrolytic capacitors are chosen as output capacitors, the ESR zero is much lower and extra capacitor C6 from COMP pin to ground is needed to stabilize the system.

The pole P3 set by R3 and C6 is given by the equation (10).

$$F_{P3} = \frac{1}{2 \times \pi \times R_3 \times C_6} \quad \dots (10)$$

The compensation values for typical output voltage application are given in the table below.

V <sub>OUT</sub>	L	C <sub>OUT</sub>	R3	C3	C6
1.8V	8.2uH	22uFx2	4.02k	5.6nF	None
2.5V	10uH	22uFx2	5.11k	5.6nF	None
3.3V	10uH	22uFx2	6.49k	5.6nF	None
5V	10uH	22uFx2	10k	5.6nF	None
2.5V	10uH	470uF AL. 30mΩ ESR	40.2k	390pF	220pF
5V	10- 15uH	470uF AL. 30mΩ ESR	150k	220pF	120pF

**PACKAGE DIMENSIONS**
**DE** Plastic SOIC 8 Pin With Exposed Pad

**Unit: mm(inch)**



NX7102

**3A High Voltage Synchronous Buck Converter**

PRODUCTION DATA SHEET

**NOTES**

PRODUCTION DATA – Information contained in this document is proprietary to Microsemi and is current as of publication date. This document may not be modified in any way without the express written consent of Microsemi. Product processing does not necessarily include testing of all parameters. Microsemi reserves the right to change the configuration and performance of the product and to discontinue product at any time.