

TRIGET

Triple Gigabit Ethernet Controller PC/104-Plus Modules

General Description

The TRIGET-Family consists of highly integrated, flexible and robust PC/104-Plus compliant Ethernet modules for industrial use. With a single PC/104-Plus module a system can be expanded with up to three Gigabit Ethernet controllers! Through the use of a PCI to PCI bridge the TRIGET requires only one slot on a PC/104-Plus stack. Therefore the stack still can be expanded by up to three other PC/104-Plus cards.

To match the different system requirements various interfaces and mechanical versions are offered. Chose between RJ45 or 2mm lockable headers as well as two mechanical sizes.

TRIGET works on 5V and 3.3V PCI host boards. Further it supports up to 66MHz PCI operation.

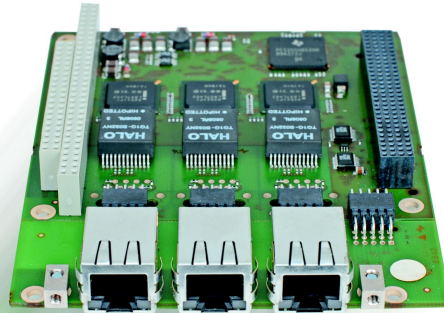

TRIGET-3M
for MPL PIP assembly

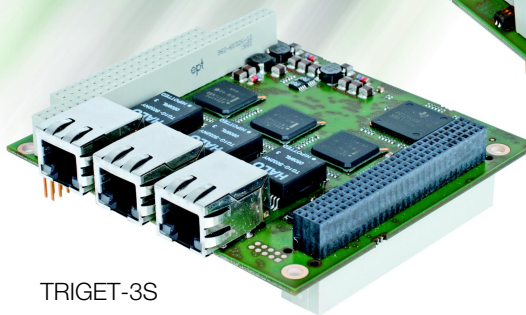

TRIGET-3S
with standard RJ45

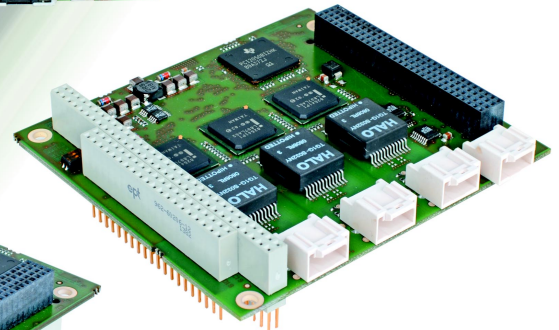

TRIGET-3H
with lockable headers

TRIGET specialties

- Up to three Gigabit Ethernet controllers
- Only one PC/104-Plus Slot is used
- Status LEDs onboard
- Ethernet over RJ45 or 2mm lockable headers
- 33MHz/66MHz PCI operation
- Single 5V power supply
- 5V tolerant 3.3V PCI signaling

Those features make

TRIGET is ideally suited for network applications that require many independent high-speed interfaces. Through the robust and flexible design the products can be well used in any embedded system.

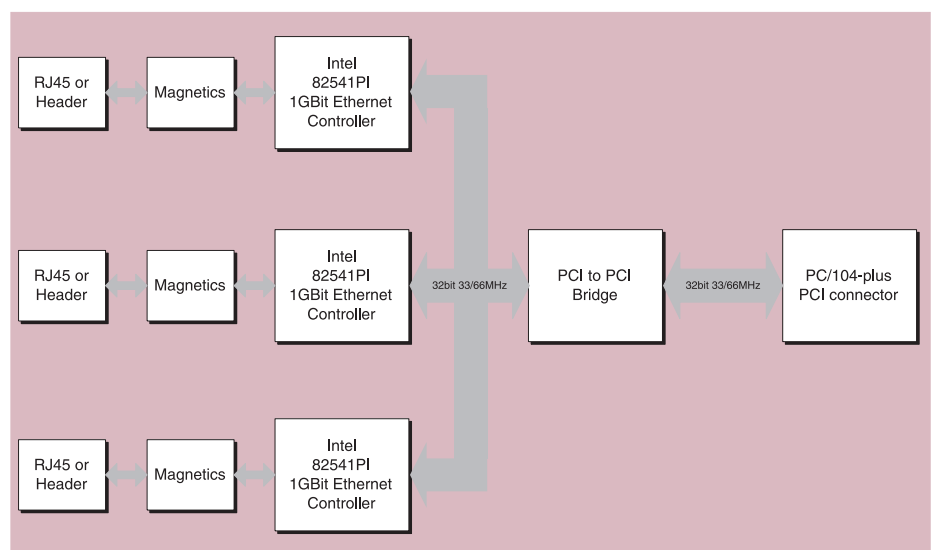

Technical Features TRIGET

Board Key Data

Network Controller	Intel 82541PI	up to three controllers onboard
Physical Interface	RJ45 or 10-pin 2mm lockable header	supports auto crossover (Auto MDI/MDIX)
Status LEDs	2 LEDs for each port	Link/Activity and Speed
Host Interface	PC/104-Plus compliant PCI specification revision 2.3 compliant	stackthrough module, up to 66MHz supports both 5.0V and 3.3V signaling
Power	Runs with 5V input power only	

Physical / Power

Size (length x width x height)	92.4 x 95.9 x 11.1 mm	2mm header version (-xH)
	90.7 x 95.9 x 13.9 mm	RJ45 version (-xS)
	122.2 x 95.9 x 13.9 mm	PIP built-in version (-xM)
Weight	100g / 0.22 lbs	fully equipped TRIGET-3S
Power	+5VDC ± 5%	input over PCI connector
Power consumption	Typically 4W	with 3x Gigabit links
Temperature Range	-20°C up to 60°C	optional -40°C up to 85°C
Humidity	5% - 95% non condensing	optional coating available

TRIGET Versions

Product number	Function
TRIGET-3H	3 Gigabit Ethernet controller on standard PC/104-Plus module. Ethernet interfaces over 2mm lockable headers.
TRIGET-3S	3 Gigabit Ethernet controller on standard PC/104-Plus module. Ethernet interfaces over RJ45 connectors.
TRIGET-3M	3 Gigabit Ethernet controller on PIP built-in PC/104-Plus based module. Ethernet interfaces over RJ45 connectors directly available on the PIP Front.
TRIGET-3HKIT	Cable and connector kit for TRIGET-3H. Small PCB with 3 Ethernet interfaces over RJ45 connectors.
TRIGET-Cx	Custom specific version with 1-3 Gigabit Ethernet controller and required Ethernet interfaces. Please talk to us.

Please note, not always all versions are available from stock.

Other MPL Peripherals

Product family	Function	Form Factor
LAN104	Single & dual 10/100 Mbit Ethernet modules	PC/104-Plus
MAGBES	Manageable Gigabit Ethernet switches with copper and fiber optic ports	PC/104
SPIDERLAN	Ethernet-Switch modules with up to 8 ports	PC/104-Plus
TX2FX	Ethernet Media Converter copper to fiber optic	Mezzanine
OSCI	Four or eight RS232/RS485/RS422 serial lines	PC/104-Plus
PATI	PowerPC controlled intelligent Analog- and Timer-IO module	PC/104-Plus
PCCARD	PCMCIA PC Card adapter with two slots	PC/104-Plus
IDE2CF / IDE2PCC	IDE to CompactFlash or PC Card adapter	PC/104

Other MPL Products

Embedded CPU Boards	Embedded, rugged Industrial CPU boards with PowerPC, x86 and ARM CPUs. Products with lowest power consumption, long-term availability and highest reliability.
Industrial PCs	Fanless, rugged Packed Industrial PCs with Intel CPUs in various housings and with many accessories. Products for extended temperature (-40° up to +75°C) and with long-term availability.
Panel PCs	Fanless, IP65/NEMA4 protected Panel PCs (all around). Solutions with 6" - 19" LCDs and Touch in special aluminum or stainless steel case.
Engineering & Support	Professional engineering, support and consulting by MPL engineers on Hardware and Software.

MPL AG is an ISO9001 certified company