

User Guide

TCB1000 Series

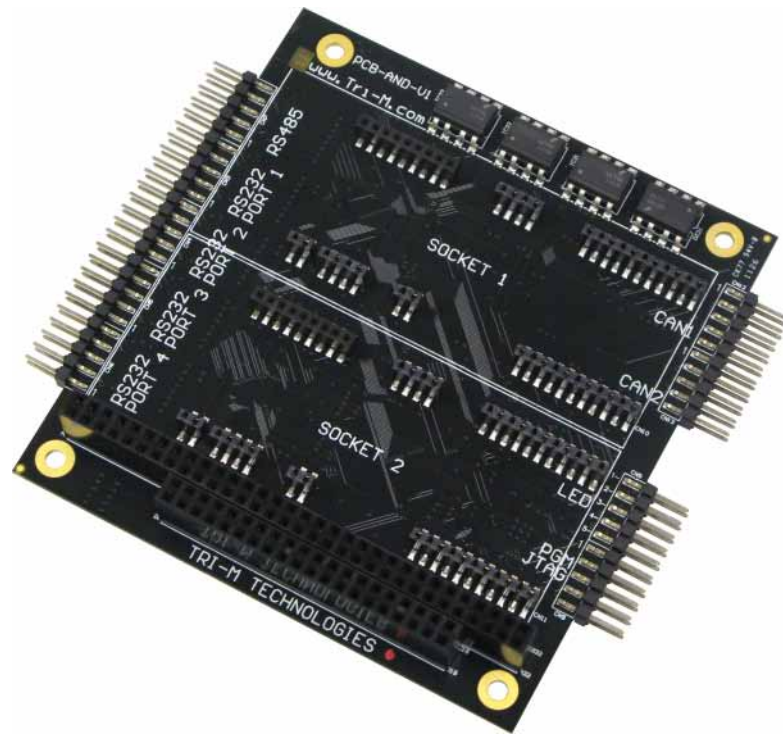

CANbus, Socket Modem & Serial Communication

Rev 09/11

Tri-M Technologies Inc.

101 – 1530 Kingsway Avenue
Port Coquitlam, BC V3C 6N6

Toll Free: 800.665.5600

Direct: 604.945.9565

Fax: 604.945.9566

Web: www.tri-m.com

Email: info@tri-m.com

Important Notes

This manual is intended for integrators of embedded system applications. It contains detailed information on hardware and software requirements to interconnect to other embedded devices. Carefully read this manual before you begin installation.

About Tri-M Technologies Inc.

Tri-M Technologies Inc. specializes in embedded computing for rugged environments. Tri-M's innovative solutions are the premiere choice for off-highway vehicles, industrial controls, robotics, military equipment, aerospace technologies, undersea and advanced security products. We offer a wide range of DC-to-DC converters, CPU boards, hardened enclosures, I/O modules, wireless communication devices, and customized systems. With over 28 years of industry experience, Tri-M is your embedded systems specialist.

Technical Support

Tri-M is pleased to provide technical support and services by phone, live chat, and email:

- For User Guides, FAQ's and RMA's, please visit us at www.tri-m.com/support
- For Email support, please contact our staff at techsupport@tri-m.com
- To speak with a technical support representative, call us at 1.800.665.5600 or +1.604.945.9565

Tri-M Technologies Inc. (Limited Warranty)

Unless otherwise agreed to in writing, Tri-M Technologies Inc. (Tri-M) warrants to the original purchaser that its products will be free from defects in material and workmanship for a period of (1) one year from the date of shipment. Tri-M's obligation under this warranty is limited to replacement or repair at its option and its designated site. Any such products must be returned within the warranty period to Tri-M in Tri-M approved packaging with a Tri-M-assigned RMA (Return Material Authorization) number referenced on the shipping documents.

All warranties are void if there is evidence of misuse, tampering, or attempted repair of parts. Any returns must be accompanied by a return material authorization (RMA) number issued by Tri-M. Purchaser shall prepay transportation to Tri-M's designated site. If returned products are repaired or replaced under the terms of this warranty, Tri-M shall pay return transportation charges.

In no case will Tri-M be held liable for consequential damages arising out of its obligations under this warranty or the failure or incorrect use of any of its products. This warranty is in lieu of all warranties, either express or implied, including, without limitation, any implied warranty of merchantability or fitness for any particular purpose, and of any other obligation on the part of Tri-M.

Disclaimer

No part of this document may be reproduced, transmitted, transcribed, stored in a retrieval system, or translated into any language or computer language, in any form or by any means, electronic, mechanical, magnetic, optical, chemical, manual, or otherwise, without the express written permission of Tri-M Technologies Inc.

Tri-M Technologies Inc. (Tri-M) makes no representations or warranties with respect to the contents of this manual, and specifically disclaims any implied warranties of merchantability or fitness for any particular purpose. Tri-M shall under no circumstances be liable for incidental or consequential damages or related expenses resulting from the use of this product, even if it has been notified of the possibility of such damages. Tri-M reserves the right to revise this publication from time to time without obligation to notify any person of such revisions.

COPYRIGHT © 2011 TRI-M TECHNOLOGIES INC.

Table of Contents

PREFACE

Important Notes	2
About Tri-M Technologies Inc.	2
Technical Support.....	2
Tri-M Technologies Inc. (Limited Warranty).....	2
Disclaimer	2

INTRODUCTION

Overview	5
Key Features	5
Optional Items.....	5
Specifications.....	6
Electrical.....	6
Mechanical	6
Environment	6
Communication	6
Certifications	6
Block Diagram	7
Dimensions	8
Connector Layout	9

CONNECTORS

Connector Specifications	10
PC/104 8bit Bus (CN1).....	10
PC/104 16bit Bus (CN2).....	11
RS232 Ports (CN3, CN4, CN5, CN6).....	12
RS485 Port (CN7)	13

JTAG Port (CN8 Top)	14
USB Port (CN8 Bottom)	14
LED Port (CN9)	15
Universal MultiTech Sockets (CN10, CN11)	16
CAN BUS (CN12, CN13)	17

CONFIGURATION

Configuration Overview	18
Command-line Configuration Setup	18
Mass-Storage Configuration Setup	19
Command-line Configuration	20
UART 1	20
UART 2	21
Serial Port Enable/Disable.....	22
DSR	22
RS485.....	23
SOCKET RESET	23
CAN MODE	24
CAN 1	24
CAN 2	25
HEART BEAT.....	25
TEMP	25
ALARM MESSAGE	26
CONFIG.....	26

APPENDIX A	27
-------------------------	-----------

Overview

Tri-M's TCB1000 Series features dual SJA1000 CANbus controllers, isolated serial ports, and two MultiTech Universal compatible sockets on a single PC/104 board design. This high density communication board offers an all-in-one communication solution, optimizing Size, Weight, and Performance (SWaP) requirements. This innovative product is an industry first, and takes full advantage of the latest technologies in jumperless configuration, high voltage isolation and advanced communication functionality.

The TCB1000 Series includes 2 galvanic isolated CANbus controllers with 2500V isolation protection and advanced networking and configuration capabilities. The 4x RS232 Ports and 1x RS485 Port features 2500V isolation protection and individual +5VDC isolated power supplies, thus providing less noise and increased system protection.

With USB connectivity and jumperless setup, extended operating temperature, and versatile options, Tri-M's TCB1000 Series is your perfect choice for CANbus, serial, and wired or wireless communication. To learn more and take advantage of this rugged and innovative design, please contact us at 1-800-665-5600 or visit us at <http://www.tri-m.com/products/trim/tcb1000.html>.

Key Features

- All-in-one PC/104 communication solution for CANbus, serial port, and wired and wireless communication (including optional GPS functionality)
- High voltage (2500V) port isolation to reduce noise and increase system protection
- Advanced CANbus functionality, such as socket network device operation, adding flexibility to your embedded system in order to reduce development time, cost, and installation setup
- Jumperless configuration with secure lock, ensuring uniformity and maximizing system security
- Extended operating temperature -40°C to +85°C (-40°F to 185°F), suited for outstanding performance and reliability in harsh environments

Optional Items

Tri-M offers the following options for the TCB1000 Series. For more information please visit us at <http://www.tri-m.com/products/trim/conformal.html> or call 1.800.665.5600.

- **Conformal Coating** (Options - CS, CH, CH1, AND CU)
Ruggedized protection against the elements such as temperature (CS), fungal resistance (CH), and humidity & chemical (CU)

Specifications

Electrical

Supply Voltage	+5 VDC
Aux Port Output Current	200mA per Port
Aux Port Output Isolation	2500V maximum

Mechanical

Dimensions	PC/104 Compliant, 90mm x 96mm x 15mm (3.55" x 3.775" x 0.6")
Weight	52g (1.9oz)

Environment

Operating Temperature	-40°C to +85°C (-40°F to 185°F)
-----------------------	---------------------------------

Communication

CANbus	2 x SJA1000 Controllers, 1Mbps maximum
RS232	4 x Isolated Ports, 921Kbp/s maximum
RS485	1 x Isolated Port, 921Kbp/s maximum
Universal MultiTech Sockets	2 x MultiTech Compatible Sockets, 921Kbp/s maximum
LED Indicators	5 x Isolated LED's, built-in limiting resistors
USB/JTAG	1 x USB/JTAG port for easy installation setup

Certifications



Manufactured in
ISO 9001:2008,
ISO 14001:2004 &
ANSI/ESD S20.20
Environments

Block Diagram

For a detailed block diagram, please see Appendix A.

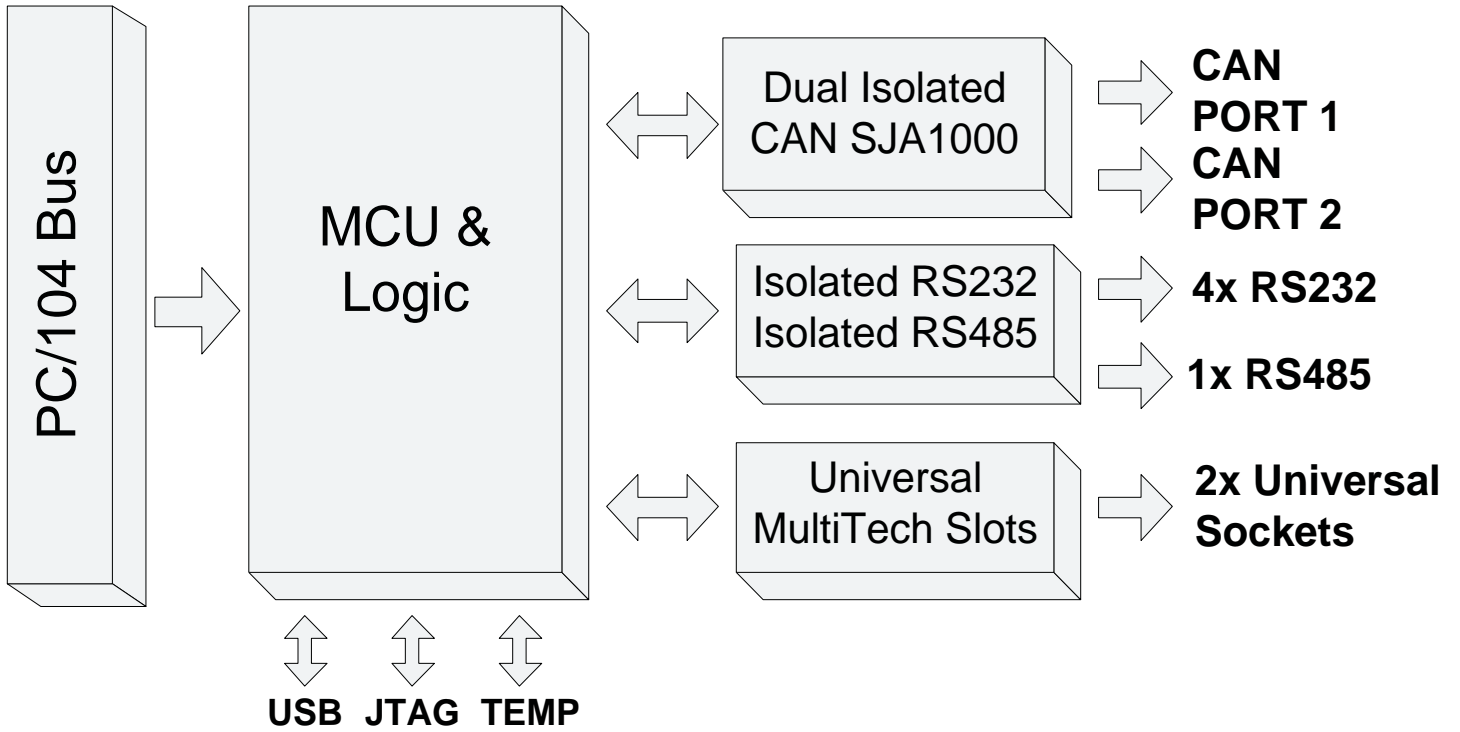

Dimensions

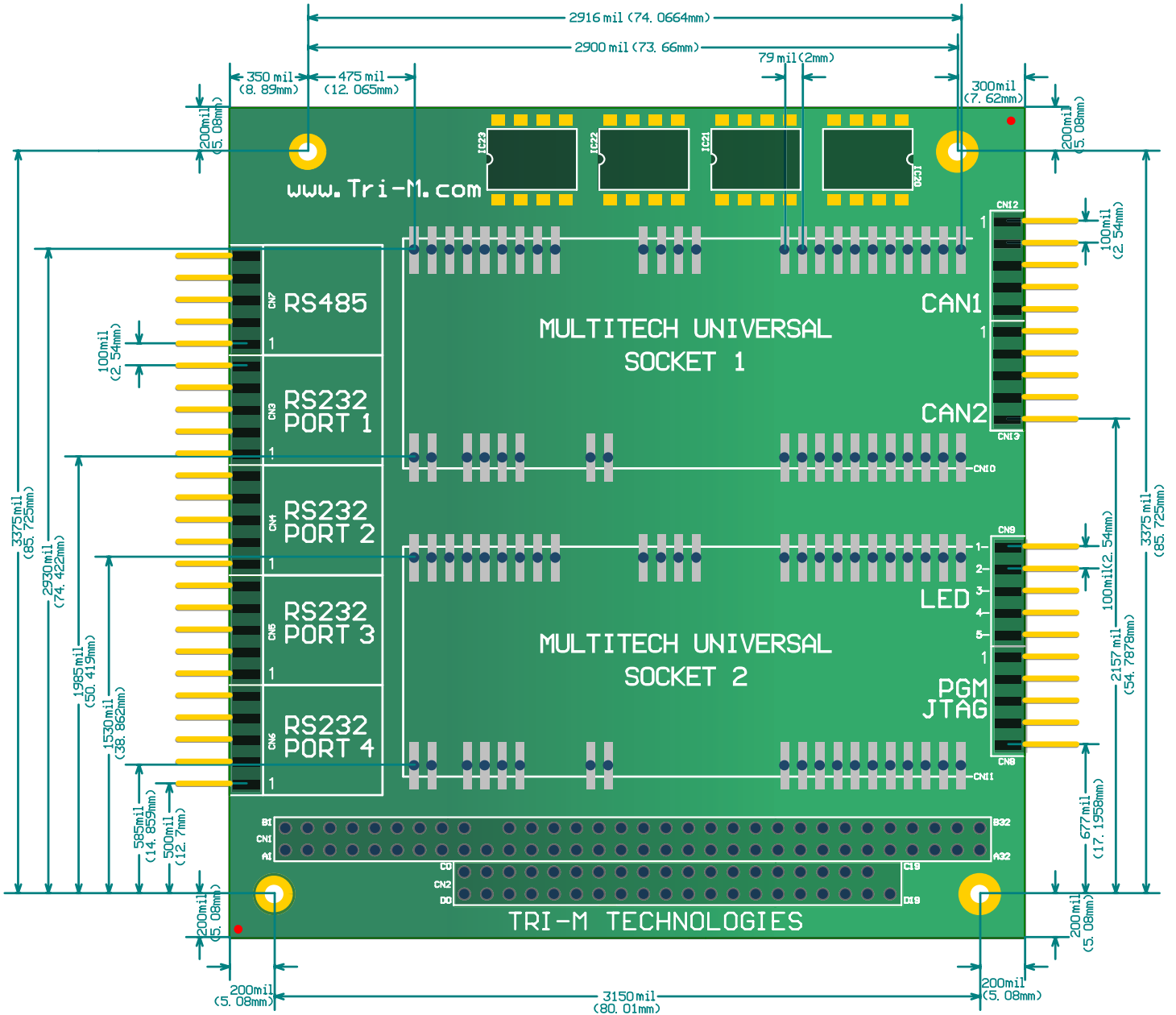

Note

Dimensions are in mil (.001 inch) and millimeters (mm)

Connector Diagram

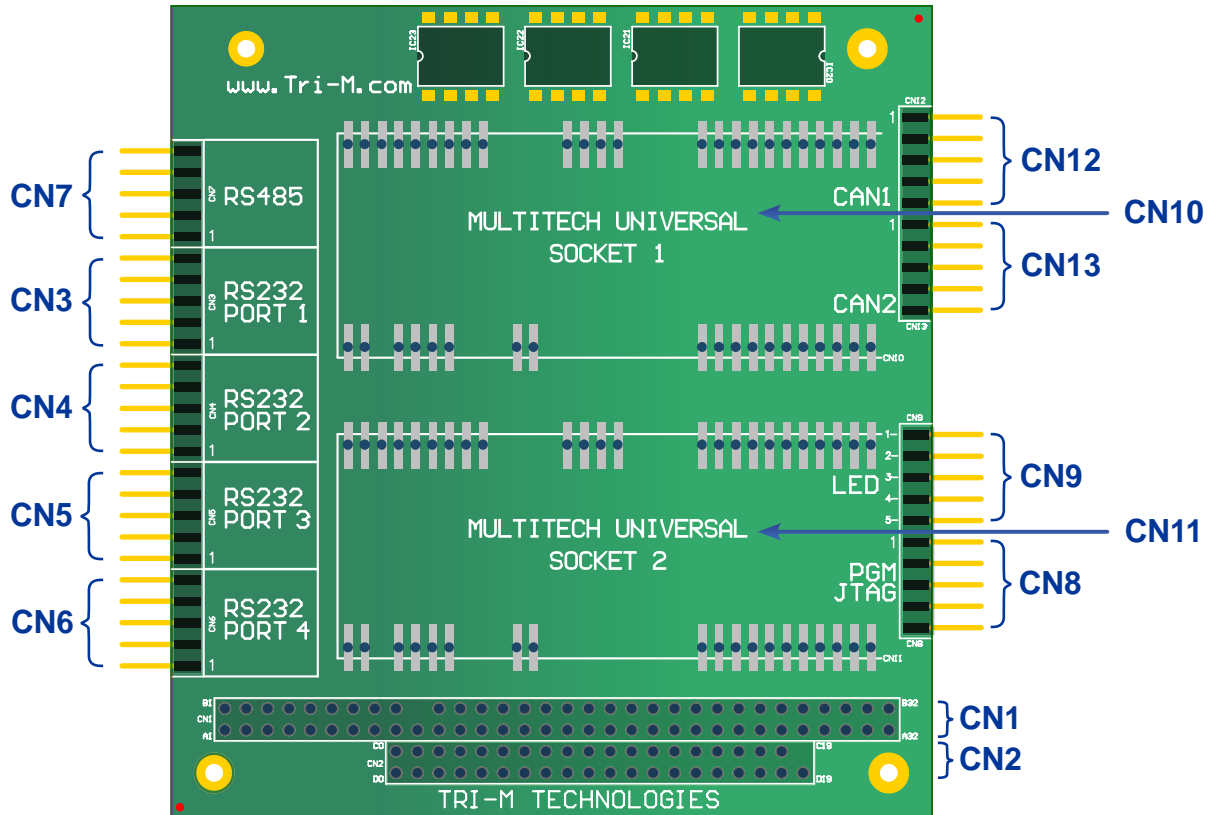

Label	Connector	Description
CN1	PC104 8-BIT BUS	2x32 press-fit header
CN2	PC104 16-BIT BUS	2x20 press-fit header
CN3	RS232 PORT 1	2x5 right-angle shroud 0.1" pins
CN4	RS232 PORT 2	2x5 right-angle shroud 0.1" pins
CN5	RS232 PORT 3	2x5 right-angle shroud 0.1" pins
CN6	RS232 PORT 4	2x5 right-angle shroud 0.1" pins
CN7	RS485 PORT	2x5 right-angle shroud 0.1" pins
CN8	JTAG (TOP) / USB (BOTTOM)	2x5 right-angle 0.1" pins (2) (Top/Bottom)
CN9	5 ISOLATED LED'S	2x5 right-angle shroud 0.1" pins
CN10	SOCKET PORT 1	Supports Tri-M and Universal MultiTech Modules
CN11	SOCKET PORT 2	Supports Tri-M and Universal MultiTech Modules
CN12	CAN BUS 1	2x5 right-angle shroud 0.1" pins
CN13	CAN BUS 2	2x5 right-angle shroud 0.1" pins

Connector Specifications

The following sections describe the mechanical and pinout specifications. For configuration and setup information, please see the Configuration section.

PC/104 8-bit Bus (CN1)

CN1 is a PC/104 ISA 8-bit bus with pass-through connectors. Tri-M also accommodates non-pass-through and non-PC/104 compliant customizations.

CN1

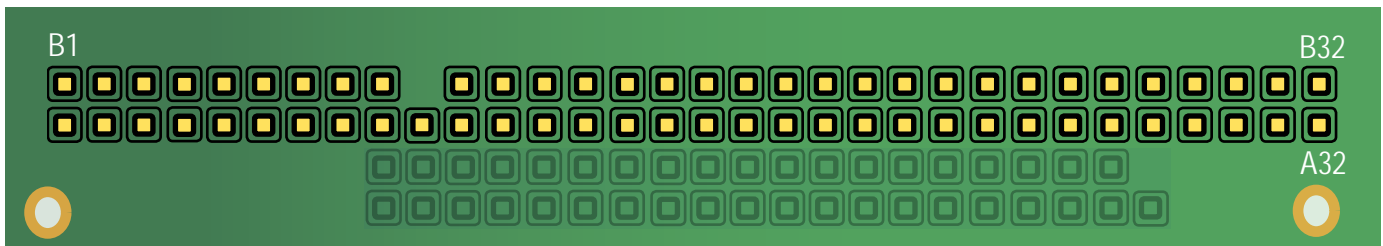

TOP VIEW

PC/104 8-bit Connector (CN1)							
Pin	Signal	Pin	Signal	Pin	Signal	Pin	Signal
A1	/IOCHCK	B1	GND	A17	SA14	B17	/DACK1
A2	SD7	B2	RESETDRV	A18	SA13	B18	DRQ1
A3	SD6	B3	+5V	A19	SA12	B19	/REFRESH
A4	SD5	B4	IRQ9	A20	SA11	B20	SYSCLK
A5	SD4	B5	-5V	A21	SA10	B21	IRQ7
A6	SD3	B6	DRQ2	A22	SA9	B22	N/A
A7	SD2	B7	-12V	A23	SA8	B23	IRQ5
A8	SD1	B8	/OWS	A24	SA7	B24	IRQ4
A9	SD0	B9	+12V	A25	SA6	B25	IRQ3
A10	IOCHRDY	B10	GND	A26	SA5	B26	/DACK2
A11	AEN	B11	/SMEMW	A27	SA4	B27	TC
A12	SA19	B12	/SMEMR	A28	SA3	B28	BALE
A13	SA18	B13	/IOW	A29	SA2	B29	+5V
A14	SA17	B14	/IOR	A30	SA1	B30	OSC
A15	SA16	B15	DACK3	A31	SA0	B31	GND
A16	SA15	B16	DRQ3	A32	GND	B32	GND

PC/104 16-bit Bus (CN2)

CN2 is a 16-bit bus with pass-through connectors. Tri-M also accommodates non-pass-through and non-PC/104 compliant customizations.

CN2

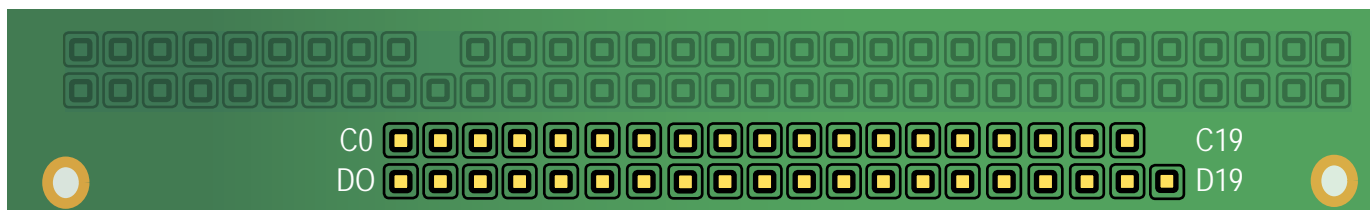

TOP SIDE

PC/104 16-bit Connector (CN2)			
Pin	Signal	Pin	Signal
C0	GND	D0	GND
C1	/SBHE	D1	/MEMCS16
C2	LA23	D2	/IOCS16
C3	LA22	D3	IRQ10
C4	LA21	D4	IRQ11
C5	LA20	D5	IRQ12
C6	LA19	D6	IRQ15
C7	LA18	D7	IRQ14
C8	LA17	D8	/DACK0
C9	/MEMR	D9	DRQ0
C10	/MEMW	D10	/DACK5
C11	SD8	D11	DRQ5
C12	SD9	D12	/DACK6
C13	SD10	D13	DRQ6
C14	SD11	D14	/DACK7
C15	SD12	D15	DRQ7
C16	SD13	D16	+5V
C17	SD14	D17	/MASTER
C18	SD15	D18	GND
C19	GND	D19	GND

RS232 Ports (CN3, CN4, CN5, CN6)

CN3 to CN6 are the RS232 Ports 1 to 4. These ports are galvanic isolated up to 2500V and have a maximum baud rate of 921Kbp/s. These isolated ports reduce noise and increases system protection. The pin spacing is 2.54mm (0.1”).

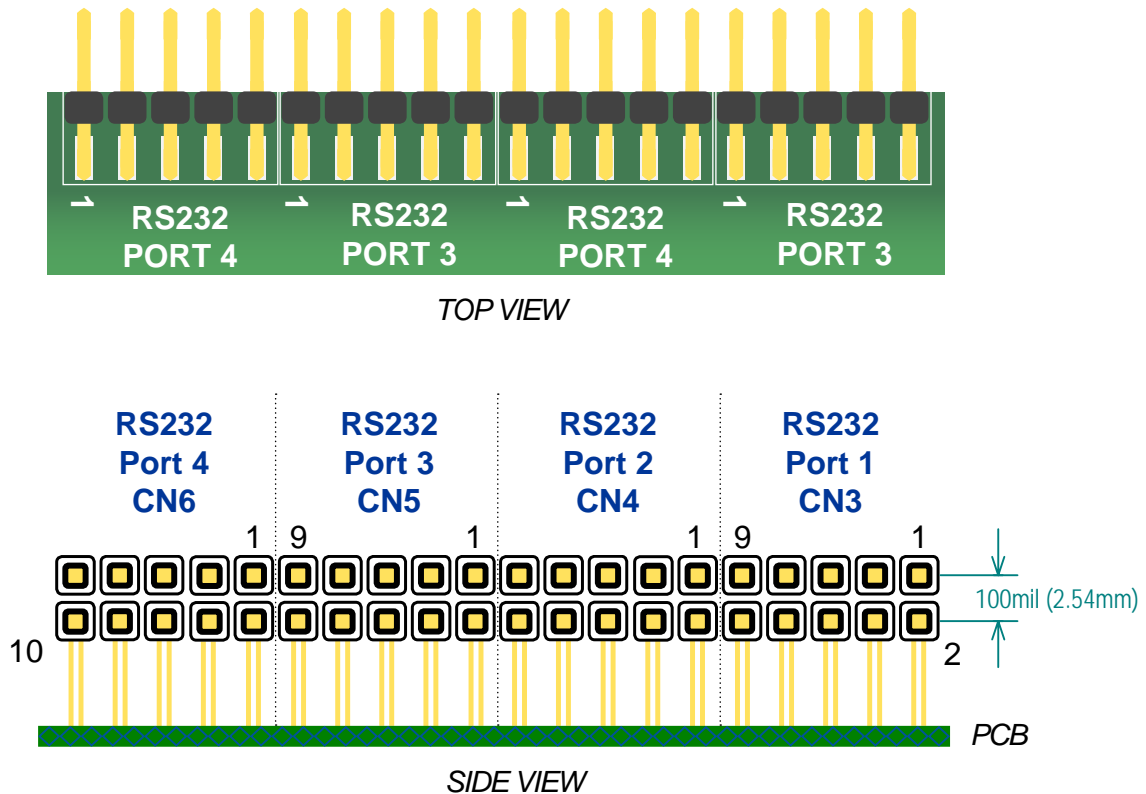

RS232 Ports 1 to 4 (CN3, CN4, CN5, CN6)			
Top		Bottom	
Pin	Signal	Pin	Signal
1	NC	2	NC
3	RX	4	RTS
5	TX	6	CTS
7	NC	8	NC
9	GNDISO	10	VCC5VISO



Note

GNDISO and VCC5VISO are independently isolated

RS485 Port (CN7)

CN7 is the RS485 Port. This port is galvanic isolated up to 2500V and has a maximum baud rate of 921Kbp/s. The port isolation reduces noise and increases system protection. The port also features a terminating 120Ω resistor setting which can be set to open or closed. Please see the Configuration section for more details. The pin spacing is 2.54mm(0.1”).

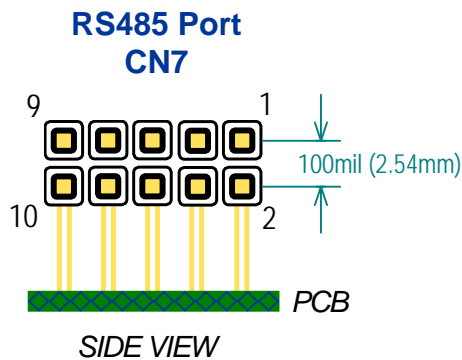
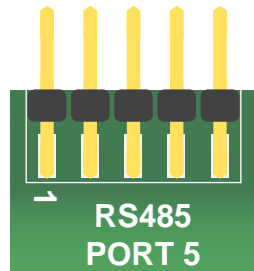

RS485 Port (CN7)			
Top		Bottom	
Pin	Signal	Pin	Signal
1	NC	2	NC
3	RX+	4	TX+
5	TX-	6	RX-
7	NC	8	Z120Ω Enable
9	GNDISO	10	VCC5VISO



Note

The software configuration command 'RSZ' will take precedence when set. Please see the Configuration section for more details.

JTAG Port (CN8 Top)

CN8 is the JTAG and USB Port comprised of two 1x5 headers. The top side of CN8 is the JTAG Port. It provides programming and debugging capabilities for the CPLD. The pin spacing is 2.54mm(0.1”).

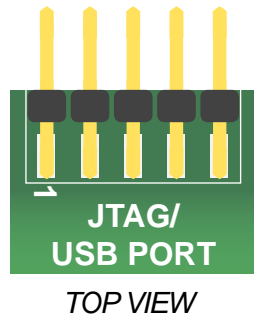

Note
This port is for factory use only.

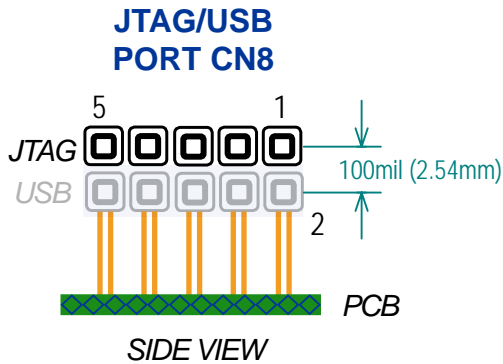

JTAG Port (CN8)	
Pin	Signal
1	VCC3V3
3	TMS
5	TCK
7	TDI
9	TDO

USB Port (CN8 Bottom)

The bottom side of CN8 is the USB Port, used to setup and configure the TCB1000. For configuration details, please see the Configuration section. The pin spacing is 2.54mm(0.1”).

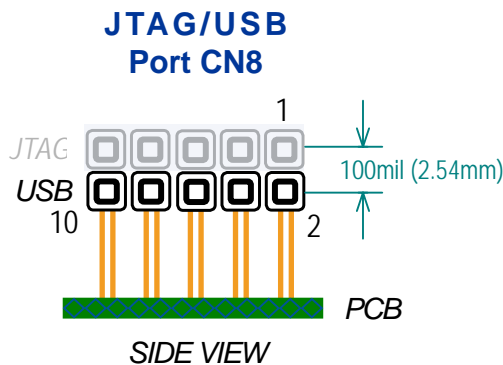

USB Port (CN8)	
Pin	Signal
2	VCCUSB
4	D-
6	D+
8	GND
10	ISP

LED Port (CN9)

CN9 are the 5 LED Ports. These ports monitor the 4x RS232 and 1x RS485 signals. They are independently isolated up to 2500V, and do not require any limiting resistors, allowing you to directly connect an LED to the port. To configure the LED's, please see the Configuration section. The pin spacing is 2.54mm(0.1").

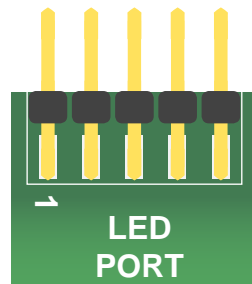

TOP VIEW

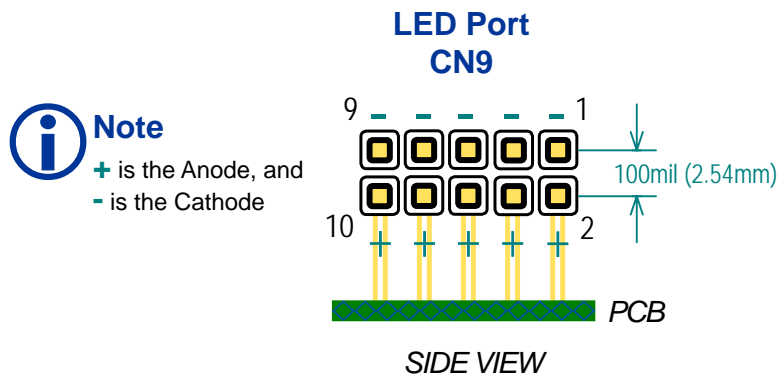

LED Port (CN9)				
	Top		Bottom	
	Pin	Signal	Pin	Signal
LED1	1	LED-	2	LED+
LED2	3	LED-	4	LED+
LED3	5	LED-	6	LED+
LED4	7	LED-	8	LED+
LED5	9	LED-	10	LED+

Note
LED- and LED+ are independently isolated

Universal MultiTech Sockets (CN10, CN11)

There are two Universal MultiTech compatible sockets capable of serial and wireless or wired communication. Tri-M developed its own GPS module and provides a variety of socket modules including Ethernet, CDMA, GSM, GPRS, Wi-Fi and Bluetooth. For specific product information, please visit <http://www.tri-m.com/products/multitech/>.

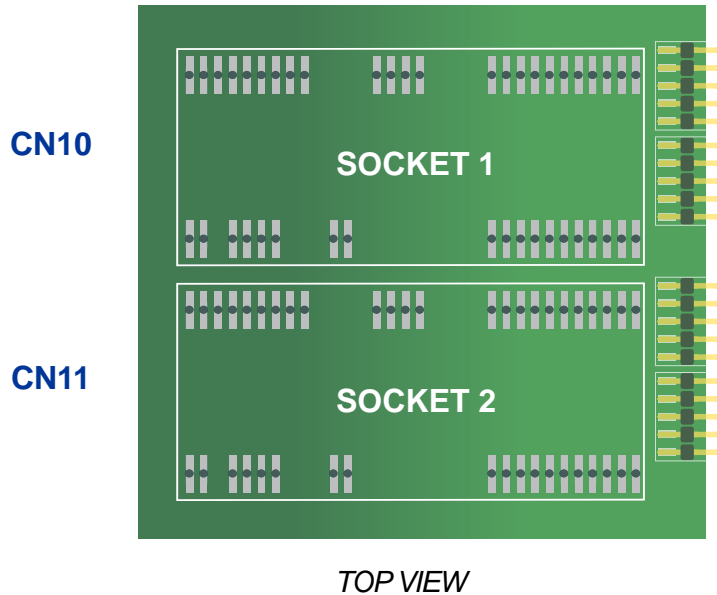

MultiTech Universal Socket	
(I/O)Tip	1
(I/O) Ring	2
Safety Void	3
(O) TX+	4
(O) TX-	5
(I) RX+	6
(I) RX-	7
Safety Void	8
	9
(O) TCLK	10
(O) RCLK	11
	12
	13
	14
	15
	16
	17
	18
	19
	20
	21
(I) MIC+	22
(I) MIC-	23
(I) -RESET	24
(I) USB_VBUS	25
(I) GND	26
(I/O) USB_DP	27
(I/O) USB_DN	28
(O) LED DCD	29
(O) LED RX	30
(O) LED DTR	31
(O) LED TX	32
	33
	34
	35
	36
	37
	38
	39
	40
	41
	42
	43
	44
	45
	46
	47
	48
	49
	50
	51
	52
	53
	54
	55
	56
	57
	58
	59
	60
	61
	62
	63
	64

CAN BUS (CN12, CN13)

There are two NXP SJA1000 Controller Area Network (CAN) controllers providing up to 2500V channel isolation and high input impedance for maximum protection in harsh environments. They are configurable for BasicCAN and PeliCAN. The pin spacing is 2.54mm(0.1”).

The CAN transceiver has thermal shutdown protection, maximum speeds up to 1 Mb/s, and slope control for EMI protection. It has a jumperless impedance setting, and unpowered nodes do not disturb the bus resulting in secure and reliable network signaling. Another great feature is the flexibility to access the CAN as a socket network device. To configure the CANbus, please see the Configuration section.

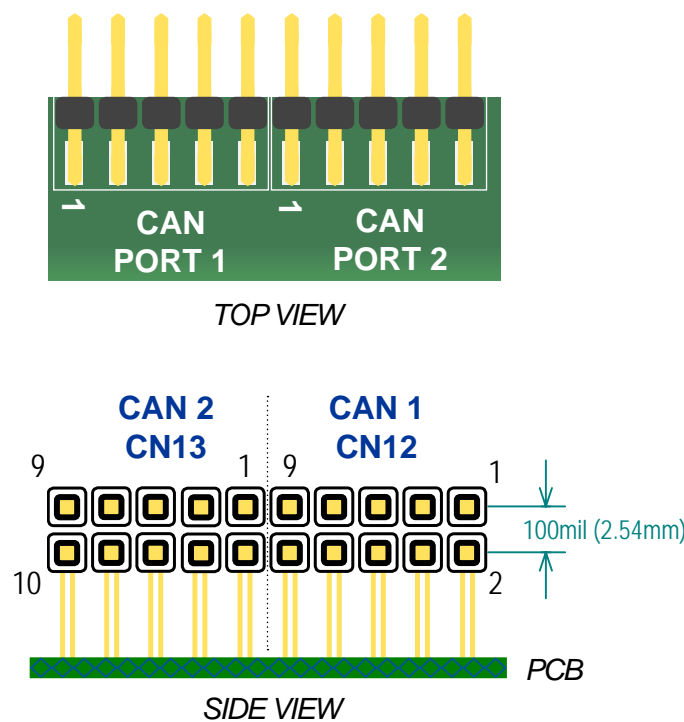

CAN BUS (CN12, CN13)			
Top		Bottom	
Pin	Signal	Pin	Signal
1	N.C.	2	GND ISO
3	CAN-	4	CAN+
5	GND ISO	6	LOAD ON
7	LOAD T	8	+5VDC ISO
9	N.C.	10	N.C.



Note

To enable Z, connect LOAD T and LOAD ON

Configuration Overview

The configuration setup uses a state of the art jumperless embedded design. This gives you quick and easy remote and direct access to the board without having to disassemble and reassemble your stack. The jumperless design is also a key element for ruggedization and protection for shock and vibration. The TCB also features a configuration lock to secure your settings from undesirable changes. There are two methods to configure the TCB1000: Command-line and Mass-Storage.

Command-line Configuration Setup

You can access the TCB's Serial Port 8 remotely or directly by connecting a USB cable. Connecting remotely involves identifying and accessing the COM port using a 'terminal' command-line application. Connecting directly entails configuring the USB cable in CDC (communication device class) mode, thus enabling a USB Virtual COM Port. You can then use a 'terminal' application to configure the device.

TCB1000 directly accessed using a USB Cable as a Virtual COM Port



TCB1000 remotely accessed via a Stack



Note

If you lock your configuration settings, they can only be unlocked using the USB Virtual COM in CDC mode

Mass-Storage Configuration Setup

Once you have determined your configuration settings using the Command-line method, you can lock your settings and export them into a 'config.txt' file. Using the USB cable in MSC (mass-storage device class) mode, you can 'drag and drop' your configuration profile to and from the device. Note that the TCB1000 does not need power in MSC mode, adding greater flexibility and ease in configuring your device.

TCB1000 configured as a Mass-Storage device



Note

You do not need to power the board when connecting the USB cable for Mass-Storage mode, and it may take up to 25 seconds to identify and mount the device (NXP LPC1342).



CAUTION

Although the device is recognized as a Mass-Storage device, space is limited, approximately 4kb. The intended use is strictly for storing the configuration file, config.txt. The Mass-Storage memory should not be used for any other purposes as if there are any other files present, they will be lost when the system power cycles.

Command-line Configuration

Once you have established connection with Serial Port 8, either directly or remotely (see the Configuration Overview section), you can use a ‘terminal’ command-line application to read and write values. The following sections describe the read and write commands.

UART 1

These commands allow you to configure UART1 which controls the RS232 Ports 1 to 4.

Read Command	Description
SER?	Displays the addresses and IRQ's used by UART1 and UART2
U1?	Displays the addresses and IRQ's used by UART1
U1P?	Displays the addresses used by UART1
U1P1?	Displays the address used by UART1 Port 1 (RS232 Port 1)
U1P2?	Displays the address used by UART1 Port 2 (RS232 Port 2)
U1P3?	Displays the address used by UART1 Port 3 (RS232 Port 3)
U1P4?	Displays the address used by UART1 Port 4 (RS232 Port 4)
U1I?	Displays the IRQ used by UART1
U1I1?	Displays the IRQ used by UART1 Port 1 (RS232 Port 1)
U1I2?	Displays the IRQ used by UART1 Port 2 (RS232 Port 2)
U1I3?	Displays the IRQ used by UART1 Port 3 (RS232 Port 3)
U1I4?	Displays the IRQ used by UART1 Port 4 (RS232 Port 4)



Note

To enter a Read Command using a terminal command-line application, type exactly what is in the column. For instance, type **SER?**, then press the **Enter key** to return the value.

Write Command	Value	Default	Description
U1P=	ADDRESS (in Hexadecimal)	0x100	Assign a base address to UART1. The value should represent the real 10bits value as it will be masked with 0x3E0. The ADDRESS RANGE is from 0x100 to 0x3E0 by steps of 0x20. For instance, 0x100, 0x120...0x3E0, 0x3C0, 0x3E0.
U1I=	IRQ	5	Assign an IRQ (5,6,7,9,10,11,12,15)



Note

ADDRESS values are encoded and must be entered in hexadecimal. IRQ values are in decimal. All other values are NUMERICAL, UPPER CASE.

UART 2

These commands allow you to configure UART2 which controls the RS485 Port, Socket Modem 1, Socket Modem 2, and CPU.

Read Command	Description
SER?	Displays the addresses and IRQ's used by UART1 and UART2
U2?	Displays the addresses and IRQ used by UART2
U2P?	Displays the addresses used by UART2
U2P1?	Displays the address used by UART2 Port 1 (RS485 port)
U2P2?	Displays the address used by UART2 Port 2 (Socket 1)
U2P3?	Displays the address used by UART2 Port 3 (Socket 2)
U2P4?	Displays the address used by UART1 Port 4 (CPU)
U2I?	Displays the IRQ used by UART2
U2I1?	Displays the IRQ used by UART2 Port 1 (RS485 port)
U2I2?	Displays the IRQ used by UART2 Port 2 (Socket 1)
U2I3?	Displays the IRQ used by UART2 Port 3 (Socket 2)
U2I4?	Displays the IRQ used by UART1 Port 4 (CPU)



Note

Write Commands do not immediately take effect until you enter the UPD (update) command or reboot the device. The configuration settings are then saved to config.txt located on the Mass Storage device.

Write Command	Value	Default	Description
U2P=	ADDRESS (in Hexadecimal)	0x200	Assign a base address to UART2. The value should represent the real 10bits value as it will be masked with 0x3E0. The ADDRESS RANGE is from 0x200 to 0x3E0 by steps of 0x20. For instance, 0x100, 0x120...0x3E0, 0x3C0, 0x3E0.
U2I=	IRQ	5	Assign an IRQ (5,6,7,9,10,11,12,15)



Note

If you enter an invalid Value, an 'unrecognized value' message will appear and the default value will be used instead.

UART CLOCK DIVIDER

These commands allows you to assign a divider value for the UART Clock (f=14.7456MHz).

Read Command	Description
UCD?	Displays the value of the divider for the UART Clock

Write Command	Value	Default	Description
UCD=	1, 2, 4 or 8	1	Assigns a value to the divider for the UART Clock (f=14.7456MHz). For instance, if UCD=1, then the UART Clock will be 14.7456MHz; if UCD=2, then f=7.3728MHz; if UCD=4, then f=3.6864MHz; if UCD=8, then f=1.8432MHz.

SERIAL PORT ENABLE/DISABLE

These commands allow you to enable or disable the 4 RS232 Ports and RS485 Port. You can also assign Serial Port 8 to be connected to the CPU or GPIO pins on the Universal Socket 2. Note that disabling the ports will also affect the power of the LED's.

Read Command	Description
RS1?	Displays the Enable/Disable status of Serial Port 1 (RS232 Port 1)
RS2?	Displays the Enable/Disable status of Serial Port 2 (RS232 Port 2)
RS3?	Displays the Enable/Disable status of Serial Port 3 (RS232 Port 3)
RS4?	Displays the Enable/Disable status of Serial Port 4 (RS232 Port 4)
RS5?	Displays the Enable/Disable status of Serial Port 5 (RS485 Port)
RS8?	Displays whether the CPU or Socket 2 is connected to Serial Port 8 (UART 2 Port 4)
RSZ?	Displays the Terminated/Open status of Serial Port 5 (RS485 port)

Write Command	Value	Default	Description
RS1=	E or D	E	Enable or disable Serial Port 1 (RS232 Port 1)
RS2=	E or D	E	Enable or disable Serial Port 2 (RS232 Port 2)
RS3=	E or D	E	Enable or disable Serial Port 3 (RS232 Port 3)
RS4=	E or D	E	Enable or disable Serial Port 4 (RS232 Port 4)
RS5=	E or D	E	Enable or disable Serial Port 5 (RS485 Port)
RS8=	C or S	C	Assigns the CPU or Socket 2 to be connected to Serial Port 8
RSZ=	T or O	O	Connect (T) / disconnect (O) the Serial Port 5 termination (RS485 Port)

DSR

These commands allow you to configure the DSR signal to the DTR for the 4 RS232 Ports and the RS485 Port.

Read Command	Description
DSR1?	Displays the Connect/Disconnect DSR signal of Serial Port 1 (RS232 Port 1) to DTR
DSR2?	Displays the Connect/Disconnect DSR signal of Serial Port 2 (RS232 Port 2) to DTR
DSR3?	Displays the Connect/Disconnect DSR signal of Serial Port 3 (RS232 Port 3) to DTR
DSR4?	Displays the Connect/Disconnect DSR signal of Serial Port 4 (RS232 Port 4) to DTR
DSR5?	Displays the Connect/Disconnect DSR signal of Serial Port 5 (RS485 Port) to DTR

Write Command	Value	Default	Description
DSR1=	C or D	D	Connect/Disconnect the DSR signal of Serial Port 1 (RS232 Port 1) to DTR
DSR2=	C or D	D	Connect/Disconnect the DSR signal of Serial Port 2 (RS232 Port 2) to DTR
DSR3=	C or D	D	Connect/Disconnect the DSR signal of Serial Port 3 (RS232 Port 3) to DTR
DSR4=	C or D	D	Connect/Disconnect the DSR signal of Serial Port 4 (RS232 Port 4) to DTR
DSR5=	C or D	D	Connect/Disconnect the DSR signal of Serial Port 5 (RS485 Port) to DTR

RS485

These commands allow you to configure the RS485 Transmit & Receive lines.

Read Command	Description
TXI?	Displays the TXDI connection (RS485 Transmit line), TXD or GND
TXE?	Displays the TXDE connection (RS485 Transmit enable), RTS or GND
RXE?	Displays the RXDE connection (RS485 Receive enable) ALWAYS or when not transmitting (!TXDE)
CTS?	Displays the connection of Serial Port 5 (RS485), RTS or CONTROLLED (by the CPU)
DLY?	Displays the controlled delay assigned to the CTS of Serial Port 5 (RS485) in milliseconds

Write Command	Value	Default	Description
TXI=	T or G	T	Assigns the TXDI connection (RS485 Transmit line) to TXD or GND
TXE=	R or T	R	Assigns the TXDE connection (RS485 Transmit enable) to RTS or GND
RXE=	A or T	A	Assigns the RXDE connection (RS485 Receive enable) to ALWAYS or when not transmitting (!TXDE)
CTS=	R or C	R	Assigns the connection of Serial Port 5 (RS485) to RTS or CONTROLLED (by the CPU)
DLY=	Time(ms)	100	Assign the controlled delay assigned to CTS of Serial Port 5 (RS485). The range is from 0-200ms. For instance, DLY=200, means that there will be a delay for 200ms.

SOCKET RESET

These commands allow you to manually reset Socket 1 or Socket 2.

Read Command	Description
S1R?	Displays the Reset status of Socket 1, Yes or No
S2R?	Displays the Reset status of Socket 2, Yes or No

Write Command	Value	Default	Description
S1R=	Y or N	N	Manually resets Socket 1
S2R=	Y or N	N	Manually resets Socket 2



Note

If the socket is reset, S1R=Y, it will remain in reset mode until S1R=N is entered.

CAN MODE

These commands allow you to configure the CANbus for BASIC or PeliCAN, PORTIO or MEMIO, and assign the same IRQ for both CAN controllers.

Read Command	Description
CI?	Displays the IRQ for both CAN controllers
CD?	Displays the CAN address PORTIO or MEMIO decoding
CM?	Displays the CAN mode of BASIC or PeliCAN

Write Command	Value	Default	Description
CI=	IRQ	10	Assigns an IRQ (5,6,7,9,10,11,12,15) for both CAN controllers
CD=	P or M	P	Assigns the CAN address decoding to PORTIO or MEMIO
CM=	B or P	P	Assigns the CAN mode to BASIC or PeliCAN

**Note**

If the address is encoded on 20bits the IOMEM bit is set. If the address is encoded on 16bits or less the IOMEM bit is cleared.

CAN 1

These commands allow you to configure the IRQ, addresses, and slew rate for CAN controller 1.

Read Command	Description
CAN?	Displays the address and IRQ for both CAN controllers
C1?	Displays the address and IRQ used by CAN controller 1
C1P?	Displays the address used by CAN controller 1
C1I?	Displays IRQ used by CAN controller 1
C1S?	Displays the Slew Rate for CAN controller 1, FAST or SLOW

Write Command	Value	Default	Description
CP=	ADDRESS	0x600(1)	Assigns the base address for both CAN controllers.
C1I=	IRQ	10	Assigns an IRQ (5,6,7,9,10,11,12,15) to CAN controller 1
C1S=	F or S	F	Assigns the Slew Rate for CAN controller 1, FAST or SLOW

**Note**

If BASIC CAN: CAN2 address= CAN1 address + 0x20, if PeliCAN
CAN2 address= CAN1 address + 0x80

CAN 2

These commands allow you to configure the IRQ, addresses, and slew rate for the CAN controller 2.

Read Command	Description
CAN?	Displays the address and IRQ used by both CAN controllers
C2?	Displays the address and IRQ used by CAN controller 2
C2P?	Displays the address used by the CAN controller 2
C2I?	Displays IRQ used by the CAN controller 2
C2S?	Displays the Slew Rate for CAN controller 2, FAST or SLOW

Write Command	Value	Default	Description
CP=	ADDRESS	0x600(2)	Assigns the base address for both CAN controllers
C1I=	IRQ	5	Assigns an IRQ (5,6,7,9,10,11,12,15) to CAN controller 2
C1S=	F or S	F	Assigns the Slew Rate for CAN controller 2, FAST or SLOW



Note

If BASIC CAN: CAN2 address= CAN1 address + 0x20, if PeliCAN
CAN2 address= CAN1 address + 0x80

HEART BEAT

These commands allow you to assign a Heart Beat frequency (in deci-Hertz, 1/10Hz) and duty cycle.

Read Command	Description
HBF?	Displays the Heart Beat frequency in dHz
HBD?	Displays the Heart Beat duty cycle in %

Write Command	Value	Default	Description
HBF=	FREQUENCY	10	Assigns the Heart Beat frequency in dHz, 0-99
HBD=	DUTY CYCLE	50	Assigns assign the Heart Beat duty cycle in %, 0-99

TEMP

These commands allow you to configure the on-board low and high limits in Kelvin.

Read Command	Description
TRD?	Returns the current on-board temperature reading in Kelvin
TAL?	Returns the temperature low limit in Kelvin
TAH?	Returns the temperature high limit in Kelvin

Write Command	Value	Default	Description
TAL=	TEMPERATURE	233	Assigns the low limit temperature in Kelvin, 0-999
TAH=	TEMPERATURE	358	Assigns the high limit temperature in Kelvin, 0-999

ALARM MESSAGE

These commands allow you to set the frequency of the alarm message in seconds(s).

Read Command	Description
AMF?	Displays the frequency of the Alarm Message in seconds(s)

Write Command	Value	Default	Description
AMF=	TIME	60s	Assigns the frequency of the Alarm Message in seconds(s), 0-60

CONFIG

These commands allow you to view the configuration settings. In addition, you can apply changes, save/load the configuration profile (Config.txt) and lock any changes.

Read Command	Description
CFG?	Displays the entire configuration settings
VER?	Displays the firmware version, revision and build
HLP?	Displays a list of all the Read and Write Commands

Write Command	Description
UPD	Applies all the Write Commands entered while the system is running
STD	Saves the configuration profile, Config.txt, located on the device, when in the Mass-Storage mode
RLD	Loads the configuration profile, Config.txt, located on the device, when in the Mass-Storage mode
LCK	Locks and prevents any configuration changes to the device

**CAUTION**

Locked configuration settings can only be unlocked by accessing Serial Port 8 from a USB Virtual COM (USB in CDC mode).

Appendix A - Detailed Block Diagram

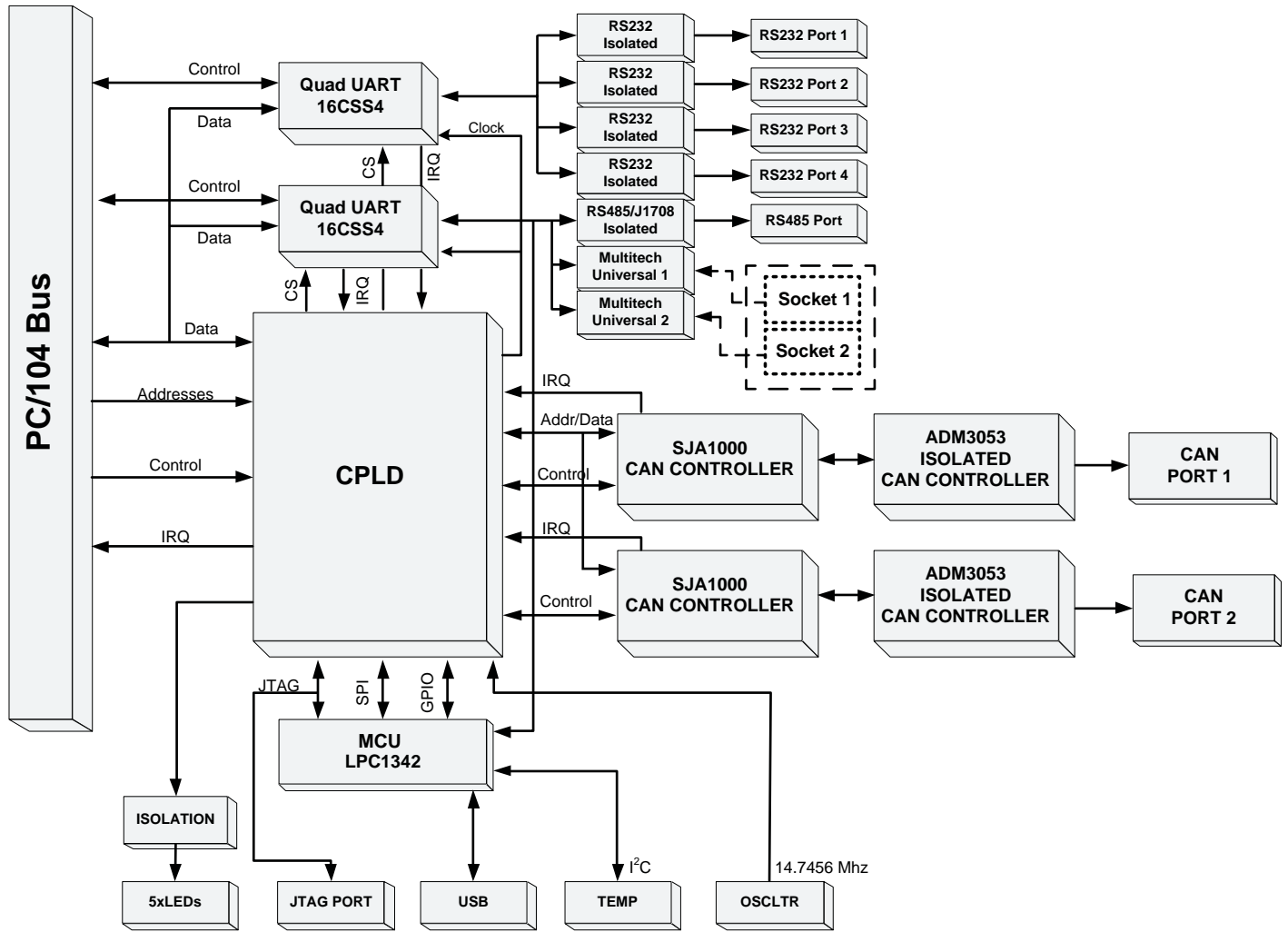

Note
For technical reference only