

Opto Coupler

OC250

Original Released: 08-21-00
Revised Date: 01-18-11

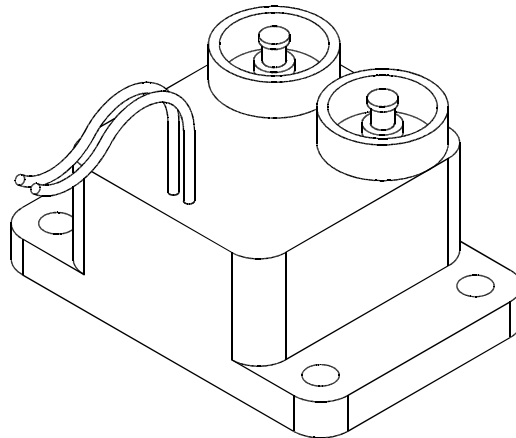
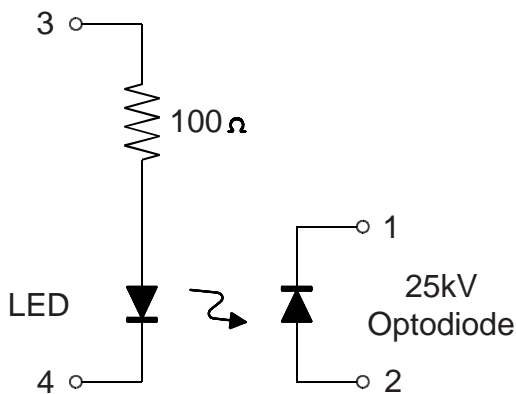

ABSOLUTE MAXIMUM RATINGS		ELECTRICAL CHARACTERISTICS	
LED		LED	
• Forward DC Current	100 mA	• Forward Voltage (If = 100 mA)	9.0 V
• Surge Current	2.5 A	• Reverse Leakage Current	10nA
• Reverse Voltage	20 V	VR = 20 V	
• Power Dissipation (25°C)	1000 mW	Photodiode	
Photodiode		• Forward Voltage (If = 0.6 A)	36 V MAX
• Reverse Voltage	25,000 V	• Reverse Leakage Current	
• Power Dissipation	2.5 W	VR = 25 kV, I _{LED} = 0 mA	250 nA Typical
<hr/>		VR = 25 kV, I _{LED} = 100 mA	100 µA Typical
• Storage Temperature	-40°C to +125°C	Coupled	
• Operating Temperature	-40°C to +100°C	• DC Current Transfer Ratio	0.064% MIN
• Isolation Test Voltage	25 kV (Pins 1 and 2 to - Pins 3 and 4)	(I _{LED} = 50 mA, VR = 10 kV)	
		• t _{ON} (Typical)	2 µs
		• t _{OFF} (Typical)	2 µs
		(25°C UNLESS OTHERWISE NOTED)	



VOLTAGE MULTIPLIERS INC.
8711 W. Roosevelt Ave.
Visalia, CA 93291

TEL 559-651-1402
FAX 559-651-0740
www.voltagemultipliers.com

OC250

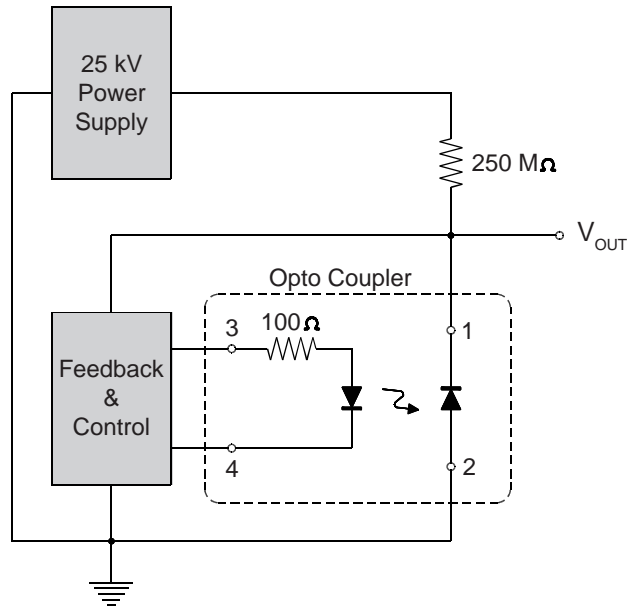
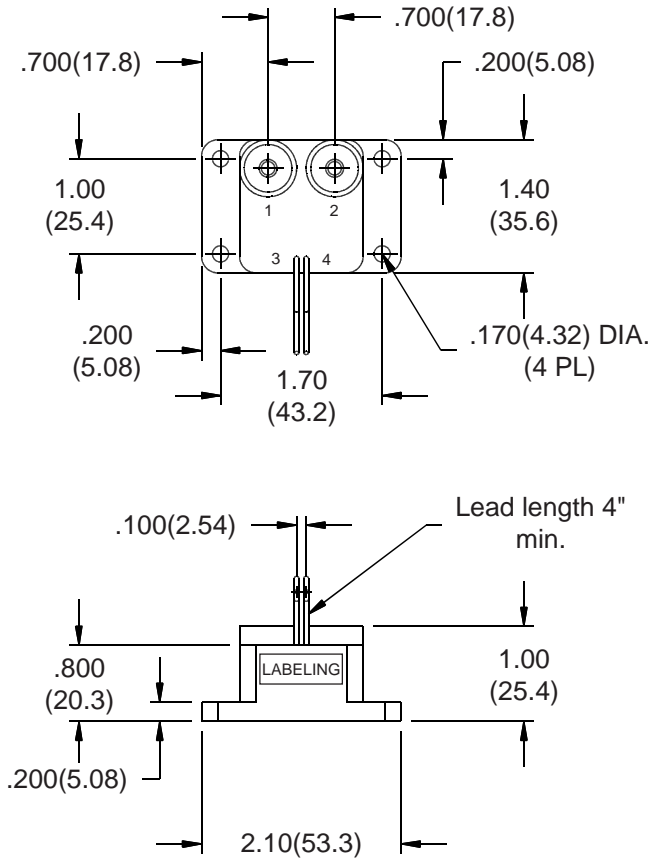

Typical HV Linear Regulator Circuit

- Select resistor value to optimize circuit for V_{OUT} and I_{OUT} range.

